

JANUARY 2015

Porta

DRILL CHUCKS & POWER TOOL ACCESSORIES MANUFACTURER

SINCE 1936

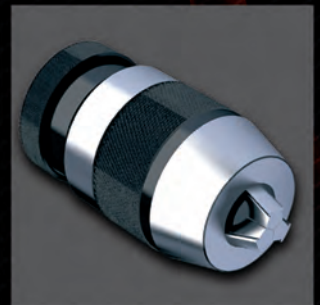
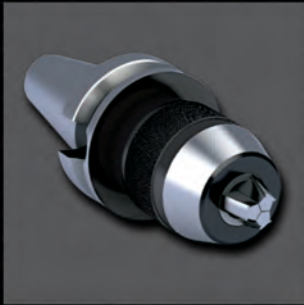
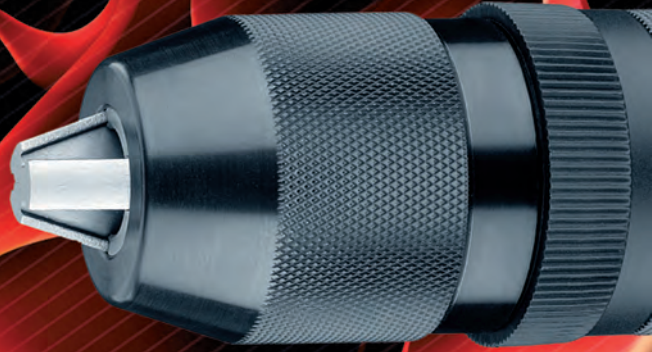



Porta s.r.l.
Via Sommariva, 33/12
10022 Carmagnola - Torino
Telefono: +39 011 97 10 018
Fax: +39 011 97 12 547
E-mail: porta@portachucks.com
www.portachucks.com



Porta (U.K.) Ltd
Dukeries Way
Dukeries Industrial Estate
Worksop, Notts S81 7DW - England
Telefono: ++44 - (0) 1909 - 530135
Fax: ++44 - (0) 1909 - 501589
E-mail: sales@portauk.co.uk
www.portaplus.co.uk

AUSTRALIA	M GAMER PTY. LTD 36 Success St. – ACACIA RIDGE Q 4110 BRISBANE Telephone +61-7-32776611 – Fax +61-7-38751531 E-mail : sales@gamer.com.au www.gamer.com.au
CANADA	MASCOUTECH INC. 998 rue Jean-Neveu - LONGUEUIL – QUÉBEC J4G 2M1 Telephone +1-450-442 4232 - Fax +1-450-442 9212 E-mail: sales@mascotech.com www.mascotech.com
FINLAND	KOIVUNEN OY P.O. BOX 115 - FI-00701 HELSINKI - FINLAND Telephone +358-10-65011– Fax +358-10-6501324 E-mail: konesasto@koivunen.fi www.koivunen.fi
FRANCE	CORI c/o WILMART ZONE INDUSTRIELLELES des Portes du Nord 62820 LIBERCOURT (FRANCE) Telephone +33-321-797474 – Fax +33-321-797479 E-mail: wilmart@wilmart.fr
GERMANY	ALWEMA GmbH Albert-Einstein-Str. 14 - 42929 Wermelskirchen Telephone +49(0)2196-8897037 – Fax +49(0)2196-8897039 E-mail: service@alwema.com www.alwema.com
ICELAND	LOGEY EHF Vesturvör 7 -200 Kopavogur – Iceland Telephone +354 5112055 – Fax +354 5112056 E-mail: logey@logey.is www.logey.is
NEW ZEALAND	TOOLWARE SALES LIMITED PO BOX 204 233 – HIGHBROOK AUCKLAND 2161 3 Stonedon Drive East Tamaki Auckland 2013 Telephone +64-9-5798080 – Fax +64-9-5262526 E-mail: info@toolware.co.nz www.toolware.co.nz
ROMANIA	CRAD RO S.R.L Str . Timis Triaj nr 6 - 500240 Brasov - Romania Telephone: 004 0268 334230 - Fax: 004 0268 334130 E-mail: info@crad.ro www.crad.ro
SOUTH AFRICA	ALLIED PUTZIGER PTY LTD T/A TOOLQUIP & P.O. BOX 5629 - 2000 JOHANNESBURG Telephone +27-11-3702727 – Fax +27-11-3702700 E-mail: info@toolquip.co.za www.toolquip.co.za
SPAIN	ASEIN INGENIEROS S.L. Enric Prat de La Riba, 10 08830 SANT BOI DE LLOBREGAT – BARCELONA Telephone: +34-93-4850143 – Fax +34-93-3091584 E-mail: asein@asein.com www.asein.com
SWITZERLAND	SCHWEIZ. MASCHINEN IMPORT AG Schanzstrasse 1 - Postfach CH-8330 Pfäffikon ZH Telephone: +41 44 953 20 20 - Fax +41 44 953 20 52 E-mail: info@smiag.ch www.smiag.ch
TURKEY	UNIVERSAL TICARET İTH.İHR. VE MUMESSİLLİK LTD.ŞTİ Fikirtepe, Özbek Caddesi No:63 A Kadıköy İstanbul Turkey Telephone: +90 216 428 35 70/+90 216 428 75 48 Fax: +00 90 216 326 51 95 E-mail: elrusso@universal-tr.com

KEYLESS DRILL CHUCKS	
Industrial line for power tools and stationary equipment	2
Industrial line for percussion power tools	3
High accuracy industrial line for machine tools and production drilling machines	3
Precision grade for CNC machine tools and machining centres standard jaws	4
Extra-torque precision grade for CNC machine tools and machining centres titanium jaws	4
Precision grade with integral shank	5
Precision grade spare chucks	5
Spanner wrench for keyless chucks with integral shank	5
Precision grade with integral shank for CNC machine tools and machining centres	6-7
Retention knobs	8
Spare parts	8
REVERSING KEYLESS CHUCKS	
TAURUS range	9-10-11-12
KEY OPERATED DRILL CHUCKS	
Medium and heavy duty line for production drilling machines, industrial and professional power tools	13
Standard duty line for portable power tools	14
Standard duty line for screwdrivers with hexagonal male mount	14
Standard duty key operated chuck nickel plated	15
Stainless steel key operated chuck for use specifically in medical, chemical and food sector	15
Chuck keys	16
MACHINE TOOLS ACCESSORIES	
Ejecting drifts	17
Right angle drill attachment	18-19
Professional right angle drill attachment	20
360° right angle drill attachment	21
Quick change SDS converter	22
Drilling and screwing bits quick change holder set	23
Rivet converter	24
Chuck adaptors	25-26
Morse taper arbors	27
Iso taper stub arbors	28
Parallel arbors with Jacobs taper mounts	28
Bridgeport R8 taper adaptors for chucks with DIN or Jacobs mount	29
Bridgeport R8 taper adaptors with Morse taper bore	29
Reducing sleeves DIN 2185	30
Reducing sleeves with plain through hole	30
Morse taper turret sockets	31
Iso taper to Morse taper adaptors	31
Extension sockets DIN 2187	32
Long pattern extension sockets	33
Lathe (dead) centres	34
Lathe centres with draw off nut according to DIN 807	35
Revolving centres	36-37
Technical information	38

Validus keyless chucks, **industrial line, self-tightening style**
for power tools, pedestal and bench drilling machines
rotary right hand rotation only

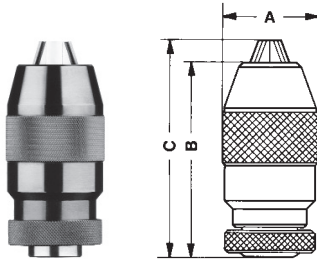

Model No.	Drilling capacity mm	Mount	A mm	B mm	C mm	Packaging style	Weight g
32B10	0-6	DIN B10	34.5	65	72	Individual box	365
32B12		DIN B12					
32J1		JACOBS 1					
32F38		Female thr. 3/8" x 24					
32F12		Female thr. 1/2" x 20					
34B10	0-8	DIN B10	34.5	65	72	Individual box	365
34B12		DIN B12					
34J2		JACOBS 2					
34J1		JACOBS 1					
34F38		Female thr. 3/8" x 24					
34F12		Female thr. 1/2" x 20					
35B12	1-10	DIN B12	34.5	72	79	Individual box	365
35J2		JACOBS 2				Individual box	
35F38		Female thr. 3/8" x 24				Individual box	
35F38B		Female thr. 3/8" x 24				Blister card	
35F12		Female thr. 1/2" x 20				Individual box	
35F12B		Female thr. 1/2" x 20				Blister card	
375B16	1.5-13	DIN B16	40.5	85	93	Individual box	540
375F38		Female thr. 3/8" x 24				Individual box	
375F38B		Female thr. 3/8" x 24				Blister card	
375F12		Female thr. 1/2" x 20				Individual box	
375F12B		Female thr. 1/2" x 20				Blister card	
37B12	1-13	DIN B12	42.5	90	101	Individual box	660
37B16		DIN B16					
37J6		JACOBS 6					
37J2		JACOBS 2					
37J33		JACOBS 33					
37F38		Female thr. 3/8" x 24					
37F12	Female thr. 1/2" x 20						
40B16	3-16	DIN B16	50.5	98	110	Individual box	1060
40B18		DIN B18					
40J6		JACOBS 6					
40J3		JACOBS 3					
40F12		Female thr. 1/2" x 20					
40F58		Female thr. 5/8" x 16					
50B22	5-20	B22	57	116	129	Individual box	1525
50J3		JACOBS 3					

new

Validus-PK keyless chucks, industrial line, self tightening style with a locking action ring suitable for percussion power tools, right hand rotation only

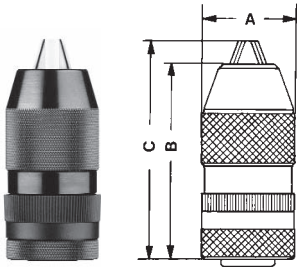

Model No.	Drilling capacity mm	Mount	A mm	B mm	C mm	Packaging style	Weight g
35PKF38	1-10	Female thr. 3/8" x 24	35.5	79.5	88	Individual box	420
35PKF12		Female thr. 1/2" x 20					410
37PKF38	1-13	Female thr. 3/8" x 24	43	86	100	Individual box	690
37PKF12		Female thr. 1/2" x 20					680
40PKF12	1-16	Female thr. 1/2" x 20	51	92.5	105	Individual box	900

Super-Validus keyless chucks, high accuracy industrial line, for machine tools and production drilling machines, self tightening style

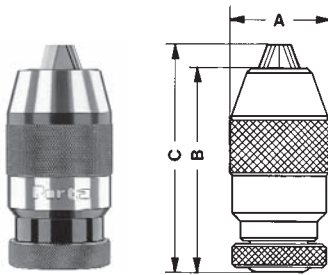

Model No.	Drilling capacity mm	Mount	A mm	B mm	C mm	Packaging style	Weight g
S24J1	0-3	JACOBS 1	24	45	49	Individual box	110
S32B10	0-6	DIN B10	36	65	73	Individual box	380
S32B12		DIN B12					
S32J1		JACOBS 1					
S34B12	0-8	DIN B12	36	65	73	Individual box	380
S34J2		JACOBS 2					
S36B16	0-10	DIN B16	45	81	93	Individual box	740
S36J2		JACOBS 2					
S36J33		JACOBS 33					
S38B16	0-13	DIN B16	51.5	93	105	Individual box	1070
S38J33		JACOBS 33					
S38J6		JACOBS 6					
S40B16	3-16	DIN B16	57.5	96	110	Individual box	1420
S40B18		DIN B18					
S40J6		JACOBS 6					

new High precision self-tightening keyless chuck with **standard** jaws
Maximum run-out 0.04mm

All components are heat treated and ground

Extremely accurate and precise chucks suitable for CNC machines and machine centres

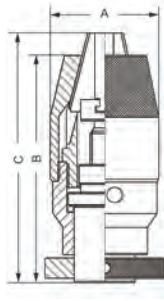

Model No.	Drilling capacity mm	Mount	A mm	B mm	C mm	Packaging style	Weight g
PP06B10	0.3-6.5	B10	33.4	62.4	68.7	Individual box	298
PP06J1		JT1					
PP08B12	0.3-8	B12	37.6	68.4	71.2	Individual box	414
PP08J1		JT1					
PP08J2		JT2					
PP10B12	0.3-10	B12	42.8	80	91.5	Individual box	637
PP10B16		B16					650
PP10J2		JT2					
PP10J33		JT33					
PP13J2	0.3-13	JT2	50.4	91.2	104	Individual box	1003
PP13J33		JT33					994
PP13J6		JT6					1003
PP13B16		B16					
PP16J6	3-16	JT6	56.7	95.5	108.9	Individual box	1298
PP16J3		JT3		101.6	104.3		1292
PP16J33		JT33		95.6	108.7		1292
PP16B16		B16		95.6	108.7		1305
PP16B18		B18		103	106.2		1319

new High precision self-tightening keyless chuck with **titanium** jaws
Maximum run-out 0.04mm

All components are heat treated and ground

Extremely accurate and precise chucks suitable for CNC machines and machine centres

Supplied with spanner wrench to allow the application of supplementary gripping torque

The high tech titanium increases the grip and wear resistance of the jaw

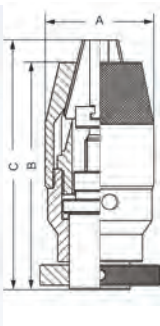

Model No.	Drilling capacity mm	Mount	A mm	B mm	C mm	Packaging style	Weight g
PPT06B10	0.3-6.5	B10	33.4	62.4	68.7	Individual box	298
PPT06J1		JT1					
PPT08B12	0.3-8	B12	37.6	68.4	71.2	Individual box	414
PPT08J1		JT1					500
PPT08J2		JT2					
PPT10B12	0.3-10	B12	42.8	80	91.5	Individual box	637
PPT10B16		B16					617
PPT10J2		JT2					700
PPT10J33		JT33					
PPT13J2	0.3-13	JT2	50.4	91.2	104	Individual box	1003
PPT13J33		JT33					994
PPT13J6		JT6					1003
PPT13B16		B16					
PPT16J6	3-16	JT6	56.7	95.5	108.9	Individual box	1298
PPT16J3		JT3		101.6	104.3		1292
PPT16J33		JT33		95.6	108.7		1305
PPT16B16		B16		95.6	108.7		1319
PPT16B18		B18		103	106.2		

Porta precision grade keyless chucks for CNC machine tools and machining centres with integral shank

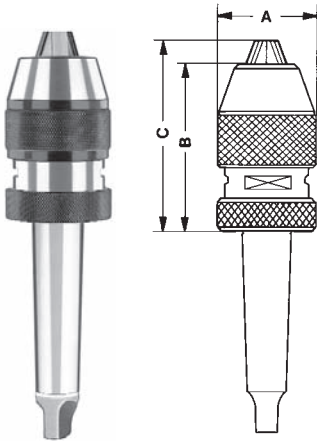

Model No.	Drilling capacity mm	Mount	A mm	B mm	C mm	Packaging style	Weight g
MT08MT2	0-8	2 Morse taper	37	67	74	Individual box	770
MT10MT2	0-10	2 Morse taper	41	81	89	Individual box	990
MT13MT2	1-13	2 Morse taper	50,5	88	99	Individual box	1200
MT13MT3		3 Morse taper					1360
MT13R8		R8 Bridgeport					1435
MT16MT2	3-16	2 Morse taper	56	95	108	Individual box	1580
MT16MT3		3 Morse taper					1690
MT16MT4		4 Morse taper					1980
MT16R8		R8 Bridgeport					1650

Porta precision grade spare chucks for integral shank keyless chucks

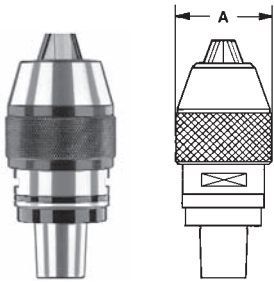

Model No.	Drilling capacity mm	Taper size	A mm	Packaging style	Weight g
MP08A	0-8	DIN B18	37	Individual box	365
MP10A	0-10	DIN B18	41		560
MP13A	1-13	3 Morse taper	46		785
* MP16A40	3-16		55		1100
** MP16A50	3-16		55		1095

* for ISO 40 taper
** for ISO 50 taper

Way of applications

Model	Model
	MP08A
	MP10A
	MP13A
	MP16A40
	MP16A50

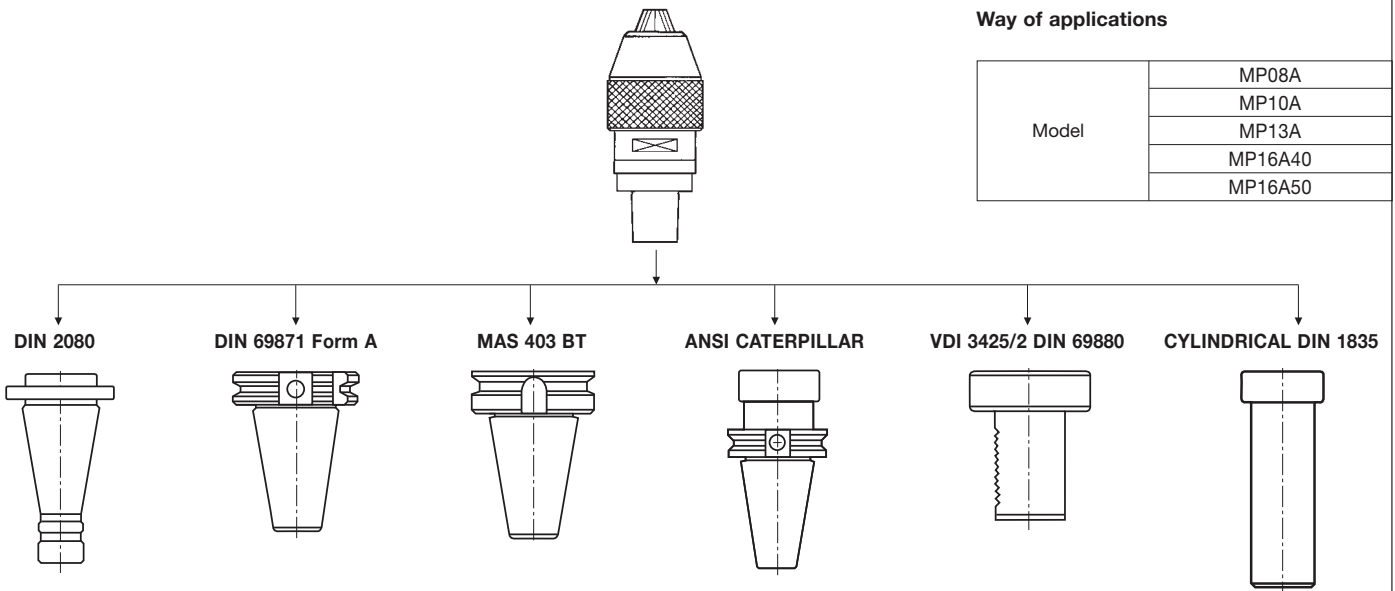

Spanner wrench for keyless chucks with integral shank



Model No.	Chuck capacity range mm
KMP08	0-8
KMP13	1-13
KMP16	3-16

Porta **precision grade** keyless chucks with **integral shank** for CNC machine tools and machining centres supplied with milled wrench flats and spanner wrench to allow the application of supplementary gripping torque

DIN 2080

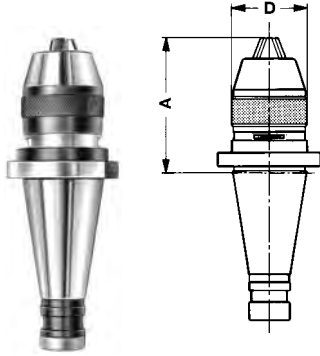

Model No.	Drilling capacity mm	Iso taper size	Drawbolt thread	D mm	A mm min	A mm max	Packaging style	Weight g
MP0840D20	0-8	40	M16	36.50	57	64	Individual box	1005
MP1340D20	1-13	40	M16	48.50	78	90	Individual box	1395
MP1350D20		50	M24		75	87		3155
MP1640D20	3-16	40	M16	54.50	90	102	Individual box	1730
MP1650D20		50	M24		72	84		3295

DIN 69871 Form A

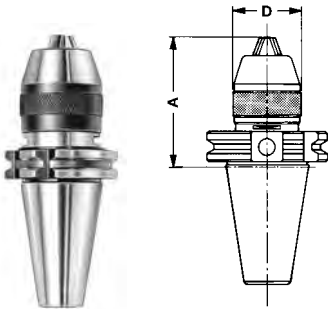

Model No.	Drilling capacity mm	Iso taper size	Drawbolt thread	D mm	A mm min	A mm max	Packaging style	Weight g
MP0840D69A	0-8	40	M16	36.50	64	71	Individual box	1005
MP1340D69A	1-13	40	M16	48.50	80	92	Individual box	1380
MP1350D69A		50	M24		78	90		3170
MP1640D69A	3-16	40	M16	54.50	97	106	Individual box	1780
MP1650D69A		50	M24		76	88		3305

MAS 403 BT

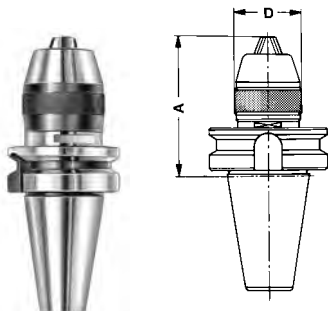

Model No.	Drilling capacity mm	Iso taper size	Drawbolt thread	D mm	A mm min	A mm max	Packaging style	Weight g
MP0830MBT	0-8	30	M12	36.50	77	84	Individual box	695
MP0840MBT		40	M16		72	79		1200
MP1340MBT	1-13	40	M16	48.50	86	98	Individual box	1535
MP1350MBT		50	M24		97	109		4135
MP1640MBT	3-16	40	M16	54.50	105	117	Individual box	1935
MP1650MBT		50	M24		95	107		4275

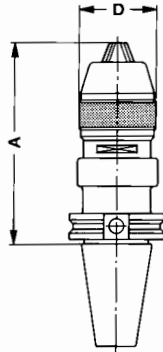

ANSI CAT

Model No.	Drilling capacity mm	Iso taper size	Drawbolt thread	D mm	A mm min	A mm max	Packaging style	Weight g
MP0840CAT	0-8	40	M16	36.50	82	89	Individual box	1255
MP1340CAT	1-13	40	M16	48.50	115	127	Individual box	1840
MP1350CAT		50	M24		96	108		3650
MP1640CAT	3-16	40	M16	54.50	120	132	Individual box	2230
MP1650CAT		50	M24		94	106		3825

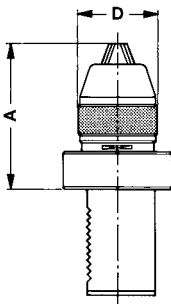

VDI 3425/2 DIN 69880

Model No.	Drilling capacity mm	Mount size	D mm	A mm min	A mm max	Packaging style	Weight g
MP1330VDI	1-13	NG16 X Ø30	48,50	108	120	Individual box	1715
MP1340VDI		NG20 X Ø40		81	93		1825
MP1640VDI	3-16	NG20 X Ø40	54,50	93	105	Individual box	2260
MP1650VDI		NG25 X Ø50		87	99		3150

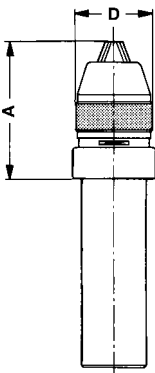

CYLINDRICAL DIN 1835

Model No.	Drilling capacity mm	Shank diameter mm	D mm	A mm min	A mm max	Packaging style	Weight g
MP0825CYL	0-8	25	36.50	65	72	Individual box	690
MP1332CYL	1-13	32	48.50	79	91	Individual box	1400
MP1340CYL		40					1890
MP1640CYL	3-16	40	54.50	83	95	Individual box	2225

Retention knobs for precision keyless chucks with integral shank

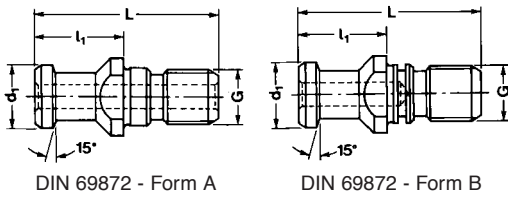

DIN 69872 - Form A

DIN 69872 - Form B

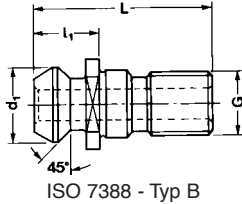

ISO 7388 - Typ B

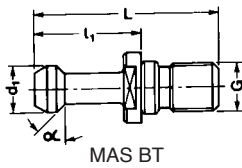

MAS BT

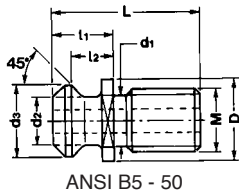

ANSI B5 - 50

Model No.	Norm	To suit Iso taper	G	d ₁ mm	L mm	l ₁ mm	a°
TD69A30	DIN 69872 - Form A	30	M12	13	44	25	-
TD69A40	DIN 69872 - Form A	40	M16	19	54	26	
TD69A50	DIN 69872 - Form A	50	M24	28	74	34	
TD69B30	DIN 69872 - Form B	30	M12	13	44	25	
TD69B40	DIN 69872 - Form B	40	M16	19	54	26	
TD69B50	DIN 69872 - Form B	50	M24	28	74	34	

Model No.	Norm	To suit Iso taper	G	d ₁ mm	L mm	l ₁ mm	a°
TS73B40	ISO 7388/2 - Typ B	40	M16	18.95	44.5	16.4	-
TS73B50	ISO 7388/2 - Typ B	50	M24	29	65.5	25.5	

Model No.	Norm	To suit Iso taper	G	d ₁ mm	L mm	l ₁ mm	a°
TMBT130	MAS BT - I	30	M12	11	43	23	45
TMBT140	MAS BT - I	40	M16	15	60	35	45
TMBT150	MAS BT - I	50	M24	23	85	45	45
TMBT230	MAS BT - II	30	M12	11	43	23	30
TMBT240	MAS BT - II	40	M16	15	60	35	30
TMBT250	MAS BT - II	50	M24	23	85	45	30

Model No.	Norm	To suit Iso taper	M	L mm	l ₁ mm	l ₂ mm	D mm	d ₁ mm	d ₂ mm	d ₃ mm
TB55040	ANSI B5-50	40	M16	38	16,4	11	22,5	12,95	12,95	18,95
TB55050	ANSI B5-50	50	M24	59	25,55	17,8	37	19,60	19,60	29,10

Spare parts for keyless chucks (no more available for Validus industrial line)

SUPER VALIDUS - page 3



Jaw carrier spindle

Drilling capacity mm	Order ref.	Jaw carrier spindle	Set of jaws
0-6		X32420S	X32120S
0-8		X34440S	X34140S
0-10		X36460S	X36160S
0-13		X38480S	X38180S
3-16		X40490S	X40190S

PP High precision self-tightening keyless chuck with STANDARD jaws - page 4



Set of jaws

Drilling capacity mm	Order ref.	Jaw carrier spindle	Set of jaws
0-8		Y54420	Y54120
0-10		Y56460	Y56160
0-13		Y58480	Y58180
3-16		Y60490	Y60190

PPT High torque/high precision keyless chuck with TITANIUM jaws - page 4

Drilling capacity mm	Order ref.	Jaw carrier spindle	Set of jaws
0-8		T54420	T54120
0-10		T56460	T56160
0-13		T58480	T58180
3-16		T60490	T60190

TAURUS range keyless chucks

Designed to exceed the performance of conventional drill chucks, the TAURUS range, represents a revolutionary new concept in technology and are precision engineered to enable the operator to lock the bit firmly in the chuck by hand.

- Suitable for Forward, Reverse and Percussion
- Nylon and Full metal version
- Double and single sleeve suitable for conventional and spindle lock machines
- Antilock mechanism
- Standard and Carbide jaw bite
- High performance for machines up to **1100 Watts** impact applications

Model numbers ending in letter R indicate chuck supplied with through hole to accommodate a left hand locking screw for reversing tools.

A TORX® wrench can also be used to lock the keyless chucks to the drilling machine spindle. No left hand screw is needed in this case.

TAURUS REGULAR

Hard nylon two piece sleeve, metal nose cap, suitable for machines in forward and reverse mode. Hand tightening style.

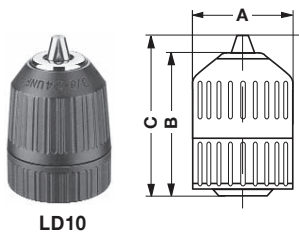

Model No.	Drilling capacity mm	Mount	A mm	B mm	C mm	Max machine rating	Packaging style	Weight g
LD10F12R	1.5-10	1/2" x 20	42.7	55	62	Suitable for machines in forward and reverse mode only	Individual box	182
LD10F12RB							Blister card	
LD10F38R		3/8" x 24					Individual box	
LD10F38RB							Blister card	

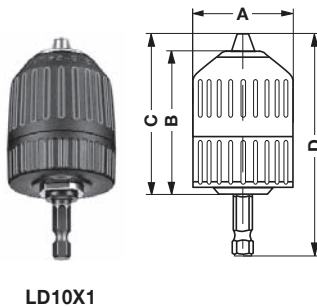

KEYLESS CHUCKS FOR SCREWDRIVERS

with 1/4" male hexagonal mount to DIN 3126 - E 6.3.

Model No.	Drilling capacity mm	A mm	B mm	C mm	D mm	Packaging style	Weight g
LD10X1B	1.5-10	42.7	55	62	80	Individual box	200

TAURUS PROFESSIONAL

Hard nylon two piece sleeve, metal nose cap, suitable for machines in forward, reverse and percussion mode. Hand tightening style.

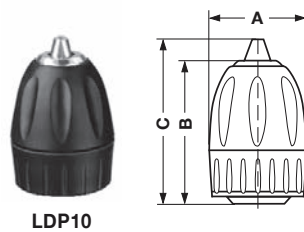

Model No.	Drilling capacity mm	Mount	A mm	B mm	C mm	Max machine rating	Packaging style	Weight g
LDP10F12R	1.5-10	1/2" x 20	42.7	55	63	450 W	Individual box	172
LDP10F12RB							Blister card	
LDP10F38R		3/8" x 24					Individual box	
LDP10F38RB							Blister card	

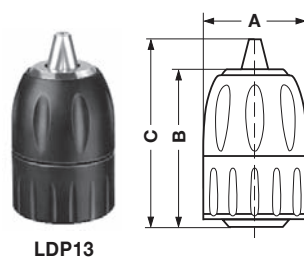

LDP13F12R	2-13	1/2" x 20	42.7	62	76	710 W	Individual box	290
LDP13F12RB							Blister card	
LDP13F38R		3/8" x 24					Individual box	
LDP13F38RB							Blister card	
LDP13SDS		SDS					Individual box	
LDP13SDSB							Blister card	

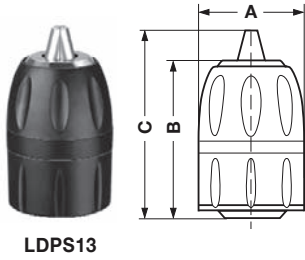

TAURUS PROFESSIONAL - SPINDLE LOCK SYSTEM

For machines with Spindle Lock system. Hard nylon single sleeve suitable for forward, reverse and percussion mode.

Model No.	Drilling capacity mm	Mount	A mm	B mm	C mm	Max machine rating	Packaging style	Weight g
LDP10SQ38	2-13	1/2" x 20	42.7	62	73	710 W	Individual box	280
LDP10SQ12RB							Blister card	

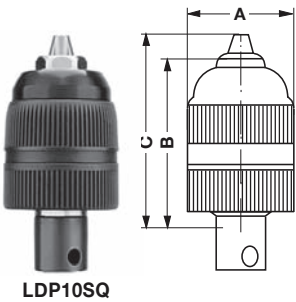

TAURUS PROFESSIONAL - FOR IMPACT DRIVERS

Model No.	Drilling capacity mm	Mount	A mm	B mm	C mm	Max torque	Packaging style	Weight g
LDP10SQ38	1-10	Quadro 3/8"	41	77	85	100 Nm	Individual box	232
LDP10SQ12		Quadro 1/2"	41	80	88			263

TAURUS SUPER suitable for forward, reverse and impact mode. standard jaws with serrated bite.

Hard nylon two piece sleeve

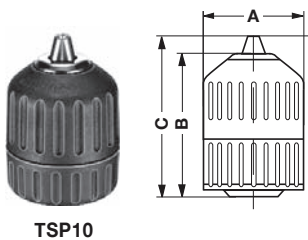

Model No.	Drilling capacity mm	Mount	A mm	B mm	C mm	Max machine rating	Packaging style	Weight g
TSP10F12R	1.5-10	1/2" x 20	42.7	55	64	1100 W	Individual box	165
TSP10F12RB							Blister card	
TSP10F38R		3/8" x 24					Individual box	
TSP10F38RB							Blister card	

Hard nylon front sleeve and rear metal sleeve

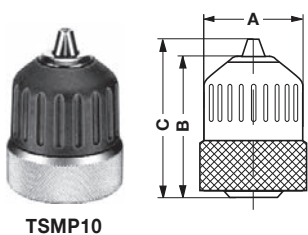

Model No.	Drilling capacity mm	Mount	A mm	B mm	C mm	Max machine rating	Packaging style	Weight g
TSMP10F12R	1.5-10	1/2" x 20	42.7	55	64	1100 W	Individual box	195
TSMP10F12RB							Blister card	
TSMP10F38R		3/8" x 24					Individual box	
TSMP10F38RB							Blister card	



TSP13

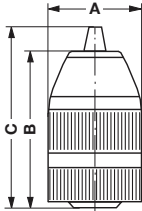

Hard nylon two piece sleeve

Model No.	Drilling capacity mm	Mount	A mm	B mm	C mm	Max machine rating	Packaging style	Weight g
TSP13F12R	1.5-13	1/2" x 20	42.7	64	75.3	1100 W	Individual box	260
TSP13F12RB							Blister card	



TS13

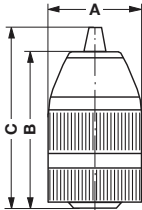

Full metal two piece sleeve

Model No.	Drilling capacity mm	Mount	A mm	B mm	C mm	Max machine rating	Packaging style	Weight g
TS13F12R	1.5-13	1/2" x 20	42.7	64	75.3	1100 W	Individual box	295
TS13F12RB							Blister card	
TS13F38R		3/8" x 24					Individual box	
TS13F38RB							Blister card	
TS13SDS		SDS					Individual box	
TS13SDSB							Blister card	

TAURUS SUPER - SPINDLE LOCK SYSTEM

For machines with Spindle Lock system, suitable for forward, reverse and impact mode. Standard jaws with serrated bite.



TSSP10

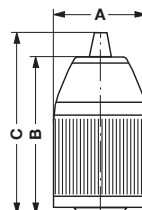

Hard nylon single sleeve

Model No.	Drilling capacity mm	Mount	A mm	B mm	C mm	Max machine rating	Packaging style	Weight g
TSSP10F12R	1.5-10	1/2" x 20	42.7	57.5	64	1100 W	Individual box	161
TSSP10F12RB							Blister card	
TSSP10F38R		3/8" x 24					Individual box	
TSSP10F38RB							Blister card	



TSS13

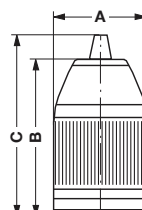

Full metal single sleeve

Model No.	Drilling capacity mm	Mount	A mm	B mm	C mm	Max machine rating	Packaging style	Weight g
TSS13F12R	1.5-13	1/2" x 20	42.7	64	75.3	1100 W	Individual box	295
TSS13F12RB							Blister card	



TAURUS ULTIMATE

Suitable for forward, reverse and impact mode.
Carbide jaw bite to ensure better gripping.

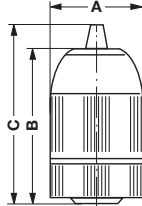

TUP13

Hard nylon two piece sleeve

Model No.	Drilling capacity mm	Mount	A mm	B mm	C mm	Max machine rating	Packaging style	Weight g
TUP13F12R TUP13F12RB	1.5-13	1/2" x 20	42.7	63.5	75.3	1100 W	Individual box Blister card	248

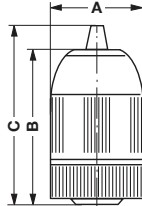

TUMP13

Hard nylon front sleeve and rear metal sleeve

Model No.	Drilling capacity mm	Mount	A mm	B mm	C mm	Max machine rating	Packaging style	Weight g
TUMP13F12R TUMP13F12RB	1.5-13	1/2" x 20	42.7	63.5	75.3	1100 W	Individual box Blister card	282

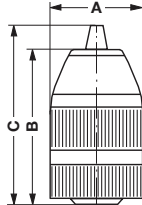

TU13

Full metal two piece sleeve

Model No.	Drilling capacity mm	Mount	A mm	B mm	C mm	Max machine rating	Packaging style	Weight g
TU13F12R TU13F12RB	1.5-13	1/2" x 20	42.7	63.5	75.3	1100 W	Individual box Blister card	282

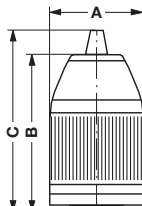

TUS13

TAURUS ULTIMATE - SPINDLE LOCK SYSTEM

For machines with Spindle Lock system, suitable for forward, reverse and impact mode. Carbide jaws.

Model No.	Drilling capacity mm	Mount	A mm	B mm	C mm	Max machine rating	Packaging style	Weight g
TUS13F12R TUS13F12RB	1.5-13	1/2" x 20	42.7	64	75.3	1100 W	Individual box Blister card	295

Key operated chucks

Medium duty for professional users of power tools, bench drilling machines, and woodworking machinery.

Heavy duty for production drilling machines and industrial power tools.

Packed in individual cartons with key

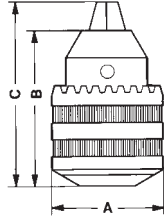

Model No.	Drilling capacity mm	Mount	Through hole diameter mm	With key	A	B	C	Range	Weight g
A04J0	0.5-4	JACOBS 0	-	K0	22	29	35	Medium duty	80
A06B10	0.3-6	DIN B10	-	KS1	32	40	50	Medium duty	135
A06J1		JACOBS 1	-						
A06F38		Female thr. 3/8" x 24	-						
A06F38R		Female thr. 3/8" x 24	5.5						
A08B12	0.3-8	DIN B12	-	KS1	30	44	54	Medium duty	140
A08J1		JACOBS 1	-						
A08F38		Female thr. 3/8" x 24	-						
A08F38R		Female thr. 3/8" x 24	5.5						
A08F12		Female thr. 1/2" x 20	-						
A08F12R		Female thr. 1/2" x 20	6.5						
AP08B12	0-8	DIN B12	-	KS2	37	51	60	Heavy duty	225
AP08J2		JACOBS 2	-						
AP08F38		Female thr. 3/8" x 24	-						
A10B12	0.5-10	DIN B12	-	KS2	37	51	60	Medium duty	220
A10J2		JACOBS 2	-						
A10F38		Female thr. 3/8" x 24	-						
A10F38R		Female thr. 3/8" x 24	5.5						
A10F12		Female thr. 1/2" x 20	-						
A10F12R		Female thr. 1/2" x 20	6.5						
AP10B16	0.5-10	DIN B16	-	KS2	43	62	76	Heavy duty	375
AP10J2		JACOBS 2	-						
A13B12	1.5-13	DIN B12	-	KS2	43	59	73	Medium duty	370
A13B16		DIN B16	-						
A13J2		JACOBS 2	-						
A13J6		JACOBS 6	-						
A13J33		JACOBS 33	-						
A13F38		Female thr. 3/8" x 24	-						
A13F38R		Female thr. 3/8" x 24	5.5						
A13F12		Female thr. 1/2" x 20	-						
A13F12R		Female thr. 1/2" x 20	6.5						
A13F14		Female thr. M14 x 2	-						
A13F18		Female thr. M18 x 2.5	-						
A13F12PKR	1.5-13	Female thr. 1/2" x 20	6.5	KS2PK	43	59	74	H.D. percussion	370
AP13B16	0.5-13	DIN B16	-	KS3	53	66	89	Heavy duty	615
AP13J6		JACOBS 6	-						
AP13J2		JACOBS 2	-						
AP13J33		JACOBS 33	-						
AP13F58		Female thr. 5/8" x 16	-						
AP16B16	2.5-16	DIN B16	-	KS3	54	67	86	Medium duty	627
AP16B18		DIN B18	-						
AP16J6		JACOBS 6	-						
AP16J33		JACOBS 33	-						
AP16F12		Female thr. 1/2" x 20	-						
AP16F12R		Female thr. 1/2" x 20	6.5						
AP16F18		Female thr. M18 x 2.5	-						
AP16F58		Female thr. 5/8" x 16	-						
AP16F58R	Female thr. 5/8" x 16	-							
APP16B18	0.5-16	DIN B18	-	KS3	57	79	102	Heavy duty	880
APP16J6		JACOBS 6	-						
APP16J3		JACOBS 3	-						
APP16F58		Female thr. 5/8" x 16	-						
AP20B22	5-20	DIN B22	-	KS4	64	92	116	Heavy duty	1095
AP20J3		JACOBS 3	-						
AP20F34		Female thr. 3/4" x 16	-	KS3	62	80	99		
AP20F58		Female thr. 5/8" x 16	-						
AP26B24	5-26	DIN B24	-	K20	75	114	139	Heavy duty	2095
AP26J4		JACOBS 4	-						

Model numbers ending in letter R indicate chuck supplied with through hole to accommodate a left hand locking screw for reversing tools. Model A13F12PKR is designed to give exceptional gripping power on heavy duty drilling applications.

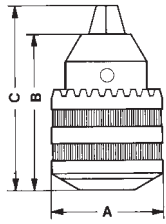

Standard duty key operated chucks the popular chucks for portable power tools

Model numbers ending in letter R indicate chuck supplied with through hole to accommodate a left hand locking screw for reversing tools.

Model No.	Drilling capacity mm	Mount	Through hole diameter mm	With key	A mm	B mm	C mm	Packaging style	Weight g
AH06F38R	0-6	Female thr. 3/8" x 24	5.5	KH810	30	40	50,5	Individual box	112
AH06F38RB								Blister card	
AH08M38	0-8	Male thr. 3/8" x 24	-	KH810	30	43	52	Individual box	135
AH08M38B		Male thr. 3/8" x 24	-					Blister card	
AH08F38		Female thr. 3/8" x 24	-					Individual box	
AH08F38R		Female thr. 3/8" x 24	5.5					Individual box	
AH08F38B		Female thr. 3/8" x 24	-					Blister card	
AH08F38RB		Female thr. 3/8" x 24	5.5					Blister card	
AH10B12	1.5-10	DIN B12	-	KH810	33	49	60	Individual box	160
AH10M38		Male thr. 3/8" x 24	-					Individual box	
AH10M38B		Male thr. 3/8" x 24	-					Blister card	
AH10F38		Female thr. 3/8" x 24	-					Individual box	
AH10F38R		Female thr. 3/8" x 24	5.5					Individual box	
AH10F38B		Female thr. 3/8" x 24	-					Blister card	
AH10F38RB		Female thr. 3/8" x 24	5.5					Blister card	
AH10F12		Female thr. 1/2" x 20	-					Individual box	
AH10F12R		Female thr. 1/2" x 20	6.5					Individual box	
AH10F12B		Female thr. 1/2" x 20	-					Blister card	
AH10F12RB		Female thr. 1/2" x 20	6.5					Blister card	
AH13B12		1.5-13	DIN B12					-	
AH13B16	DIN B16		-	Individual box					
AH13M38	Male thr. 3/8" x 24		-	Individual box					
AH13M38B	Male thr. 3/8" x 24		-	Blister card					
AH13F38	Female thr. 3/8" x 24		-	Individual box					
AH13F38R	Female thr. 3/8" x 24		5.5	Individual box					
AH13F38B	Female thr. 3/8" x 24		-	Blister card					
AH13F38RB	Female thr. 3/8" x 24		5.5	Blister card					
AH13F12	Female thr. 1/2" x 20		-	Individual box					
AH13F12R	Female thr. 1/2" x 20		6.5	Individual box					
AH13F12B	Female thr. 1/2" x 20		-	Blister card					
AH13F12RB	Female thr. 1/2" x 20		6.5	Blister card					
AH13SDS	SDS		6.5	Individual box					
AH13SDSB	SDS		6.5	Blister card					
AH16F12R	3-16	Female thr. 1/2" x 20	6.5	KS3	49.4	69	87.5	Individual box	604



AH13SDS

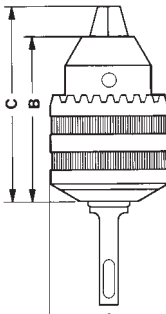

Key operated chucks for screwdrivers with 1/4" hexagonal male mount to DIN 3126 - E 6.3

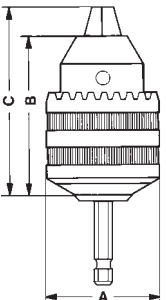

Model No.	Drilling capacity mm	With key	A mm	B mm	C mm	Packaging style	Weight g
AH06X1	0-6	KH810	30	40	50.5	Individual box	126
AH06X1B						Blister card	
AH08X1	0-8	KH810	30	43	52	Individual box	135
AH08X1B						Blister card	
AH10X1	1.5-10	KH810	33	49	60	Individual box	180
AH10X1B						Blister card	

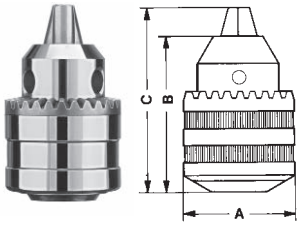

Standard duty key operated chucks nickel plated

new

Model No.	Drilling capacity mm	Mount	Through hole diameter mm	With key	A mm	B mm	C mm	Packaging style	Weight g
AH06F38RNP	0-6	Female thr. 3/8" x 24	5.5	KH810	30	40	50.5	Individual box	107
AH10F38RNP	1.5-10	Female thr. 3/8" x 24	5.5		33	40	58.6		120
AH10F12RNP		Female thr. 1/2" x 20	6.5						

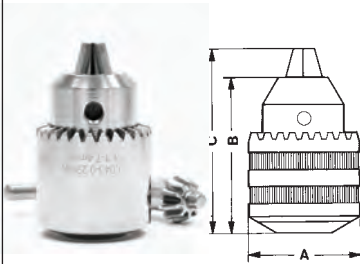

Stainless steel key operated chucks for use specifically in medical, chemical and food sector

new

Model No.	Drilling capacity mm	Mount	With key	A mm	B mm	C mm	Packaging style	Weight g
SSA04J0	0.3-4mm	JT0	SS-K0	22	28	35	Individual box	66
SSA06J1	0.3-6.5mm	JT1	SS-S1	28.5	40.5	49		165
SSA06F38		3/8-24UNF						170
SSA10J2	0.3-10mm	JT2S	SS-S2	39	51	63		295
SSA10F38		3/8-24UNF						

Chuck keys



Model No.	Key model	Standard	A mm	Teeth No.	For key chucks type	Packaging style	Weight g
KS1	KS1	DIN S1	4	10	A06-A08	Bulk	10
KS1B						Blister card	
KS1P50						50 pcs. box	
KS2	KS2	DIN S2	6	12	AP08-AP10-A10 A13-A16-AH13	Bulk	40
KS2B						Blister card	
KS2P50						50 pcs. box	
KS2PK	KS2PK	DIN S2	6	12	A13F12PKR	Bulk	59
KS3	KS3	DIN S3	8	12	AP13-AP16 APP16	Bulk	80
KS3B						Blister card	
KS3P25						25 pcs. box	
KH810	KH810	DIN S14	6	11	AH08-AH10	Bulk	20
KH810B		JACOBS KG				Blister card	
KH810P50		JACOBS KG				50 pcs. box	
K20	K20	DIN S13 JACOBS K4	9,5	12	AP26	Bulk	120
KS8	KS8	DIN S8 JACOBS K30S	6	10	Black & Decker 13 mm	Bulk	40
KS8B						Blister card	
KS8P50						50 pcs. box	
K1	K1	DIN S7 JACOBS K1	4	11	-	Bulk	10
K1B						Blister card	
K2	K2	JACOBS K2	6,3	11	-	Bulk	40
K2B						Blister card	
K32	K32	DIN S9 JACOBS K32	6,3	10	-	Bulk	60
K32B						Blister card	
KS10	KS10	DIN S10 JACOBS K3	8	11	-	Bulk	70
KS10B						Blister card	
KS4	KS4	DIN S4	9	14	AP20	Bulk	150
KS4B						Blister card	
K0	K0	JACOBS K0	3	11	A04	Bulk	20
K0B						Blister card	
KJ6	KJ6	CK-3	4	12	Makita 6 mm	Bulk	36
KJ6B						Blister card	
KJ10	KJ10	CK-4	5,5	12	Makita 10 mm	Bulk	53
KJ10B						Blister card	
KJ13	KJ13	CK-5	6,5	12	Makita 13 mm	Bulk	61
KJ13B						Blister card	
KL0	Rubber strap to attach key on power tool cable					Bulk	-

Morse taper ejecting drifts according to DIN 317, hardened and black oxide special steel



Model No.	Morse taper	Lenght mm	Packaging style	Weight g
DR0	0	90	Bulk	14
DR12	1-2	140		70
DR23	2-3	148		80
DR34	3-4	190		150
DR45	4-5	225		310
DR56	5-6	265		650

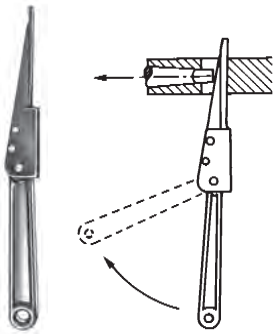

Automatic Morse taper ejecting drifts

Model No.	Morse taper	Lenght mm	Packaging style	Weight g
DRA123	1-2-3	320	Bulk	320
DRA456	4-5-6	380		580

Nail attachment with SDS adaptor to be fitted in a percussion power tool. A magnetic disc on front side provide nail catching for a quick and easy riveting.



Model No.	A mm	B mm	C mm	D mm	E Max size of nail head mm	Packaging style	Weight g
NASDS	23	29	78	13	10	Individual box	100
NASDSB						Blister card	

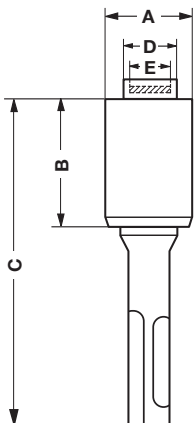



- The right angle drill attachment enables drilling of holes where no other conventional drill will fit.
- Fits to any drill with 10 mm or larger capacity chuck.
- The right angle drill attachment is equipped with a 3/8" x 24 threaded mount and can be supplied:
 - 1) Without chuck code RADA
 - 2) With key type chuck code RADACK
 - 3) With keyless chuck code RADACL
- Double heat treated helical gear.
- Aluminum alloy metal housing industrial quality guaranteed.
- Gear ratio 1:1,3
- Max drilling capacity:
 - 10 mm in steel
 - 16 mm in wood.
- Maximum speed: 2.100 rpm.
- Max torque: 29,4 Nm.

Model No.	Packaging style	Weight g
RADA	Individual box	310
RADAB	Blister card	



RADA

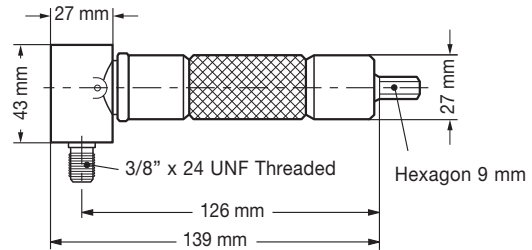

This model for screw driving applications only. It's equipped with magnetic hexagon hole to insert screwing bits.

Model No.	Packaging style	Weight g
RADAX	Individual box	315
RADAXB	Blister card	



RADAX

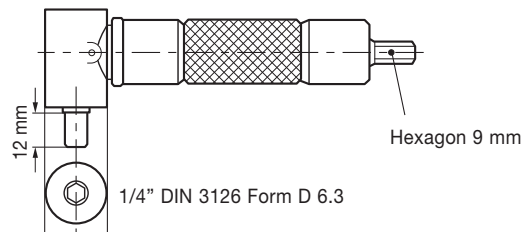

RADAV

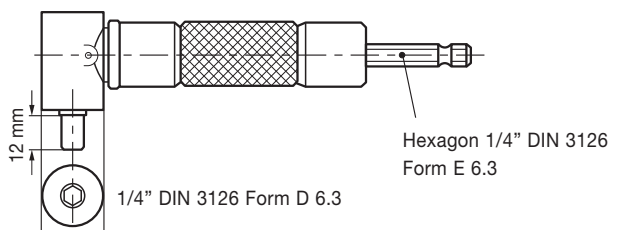

Model No.	Packaging style	Weight g
RADAV	Individual box	315
RADAVB	Blister card	

Model No.	Packaging style	Weight g
RADACK	Individual box	455



RADACK

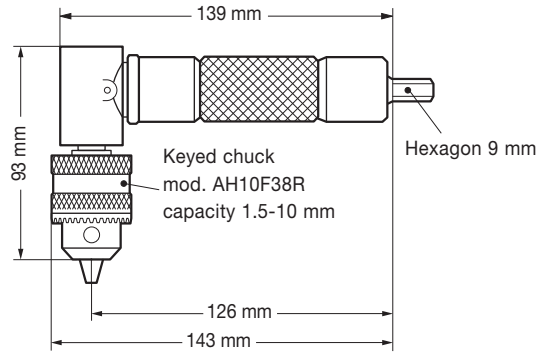

Model No.	Packaging style	Weight g
RADACL	Individual box	490



RADACL

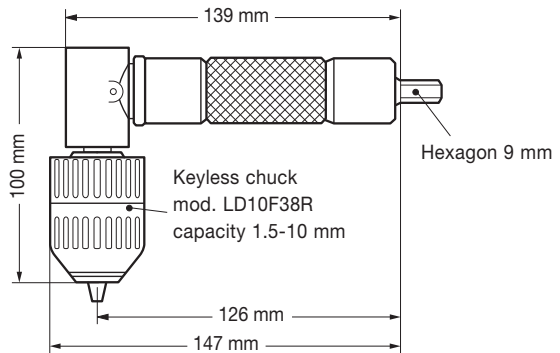

Spare parts

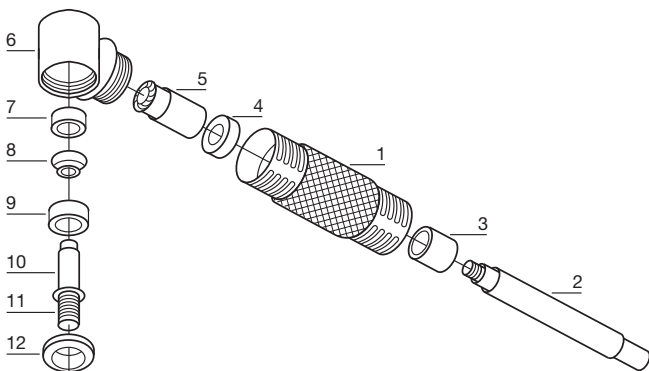

Model No.	Item No.	Description	Quantity
XRADA01	1	Body with bushing	1
XRADA02	2	Clutch pin	1
XRADA03	3	Needle bearing	1
XRADA04	4	Ball bearing	1
XRADA05	5	Bevel gear pin	1
XRADA06	6	Angle head	1
XRADA07	7	Ball bearing	1
XRADA08	8	Bevel gear	1
XRADA09	9	Ball bearing	1
XRADA10	10	Key	1
XRADA11	11	Chuck casing	1
XRADA12	12	Bearing cap	1

Professional right angle drill attachment



new

Model No.	Packaging style	Weight g
RADAQXPRO	Individual box	689

Heavy duty Professional RADA with quick release bit holder (9H) and handle.

MAX Torque 100 N.m.

Gear Ratio: 1:1.28

Code: RADAQXPRO



new

Model No.	Packaging style	Weight g
RADAPRO	Individual box	670

Heavy duty Professional RADA with 3/8" x 24 threaded head to fasten a chuck and handle.

MAX Torque 100 N.m.

Gear Ratio: 1:1.28

Code: RADAPRO

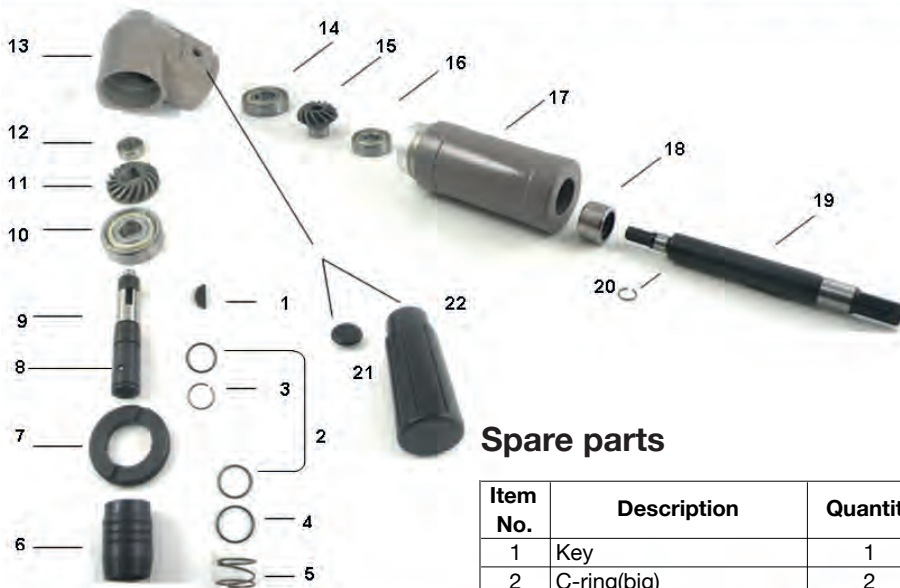

Spare parts

Item No.	Description	Quantity	Item No.	Description	Quantity
1	Key	1	12	Bearing	1
2	C-ring(big)	2	13	Angle Head	1
3	C-ring(mid)	1	14	Bearing	1
4	Washer	1	15	Gear	1
5	Spring	1	16	Bearing	1
6	Shell of quick release	1	17	Body With Bushing	1
7	Bearing Cap	1	18	Bearing	1
8	Ball	2	19	Clutch Pin	1
9	Chuck Casing	1	20	C-ring(small)	1
10	Bearing	1	21	Dust plug	3
11	Gear	1	22	Handle	1

360° right angle drill attachment

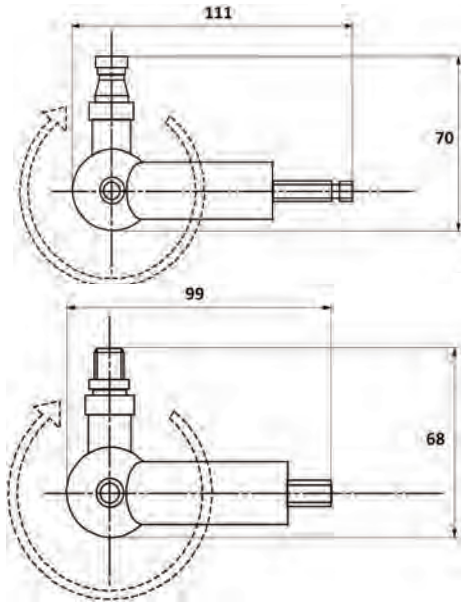

- This right angle drill attachment with a 360° full rotation enables drilling of holes and screwdriving where no other conventional drill will fit.
- It can be fitted on all standard power tools and screwdrivers.
- A T Key wrench available in the package can lock the tool at the desired angle.

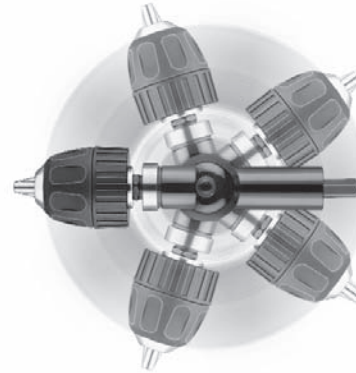

ON DRILLING POWER TOOLS

- max. speed: 3500 rpm
- max torque: 35 Nm

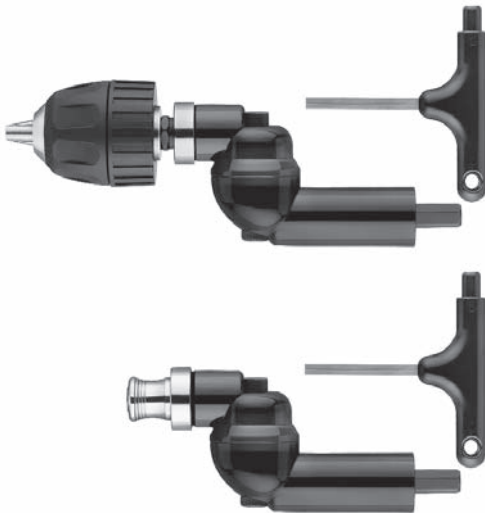

DRILLING HOLES

Mod. **RADA360CL**
With a keyless chuck mod. LD10F38R
cap. 1.5-10 mm

Packaging style: individual box
Weight g: 465

SCREWDRIVING

Mod. **RADAQ360**
With a quick change chuck for bits

Packaging style: individual box
Weight g: 301

ON SCREWDRIVERS

- max. speed: 3500 rpm
- max torque: 35 Nm

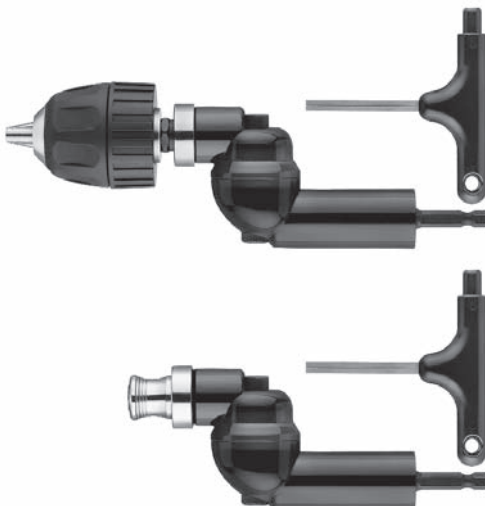

DRILLING HOLES

Mod. **RDAV360CL**
With a keyless chuck mod. LD10F38R
cap. 1.5-10 mm

Packaging style: individual box
Weight g: 465

SCREWDRIVING

Mod. **RADAQV360**
With a quick change chuck for bits

Packaging style: individual box
Weight g: 301

**Quick change SDS converter
for regular percussion power tools**



This converter adapts regular percussion impact machines to receive SDS shank tools. Quick change of SDS shank tools through the axial sliding releasing ring. Robust all steel production.

Model No.	Power tool nose	A mm	B mm	C mm	D mm	Packaging style	Weight g
SDSCONV	1/2" x 20	22	28	30	58	Individual box	160
SDSCONVB						Blister card	

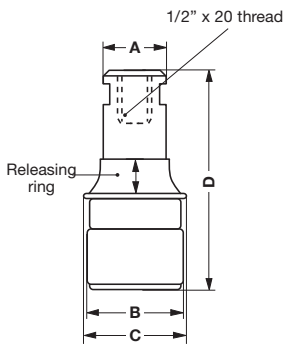

DIFFERENT WAYS OF APPLICATION

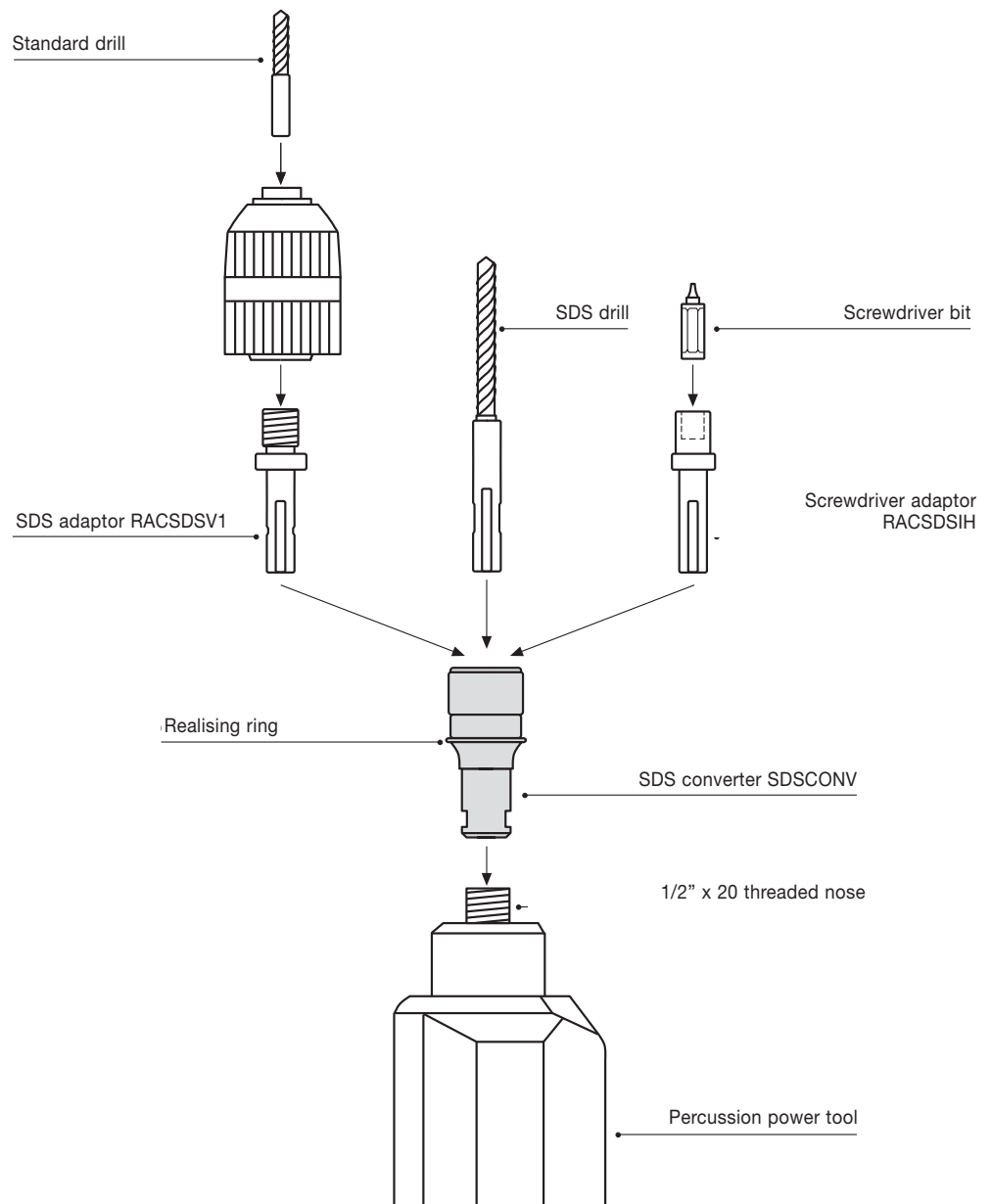

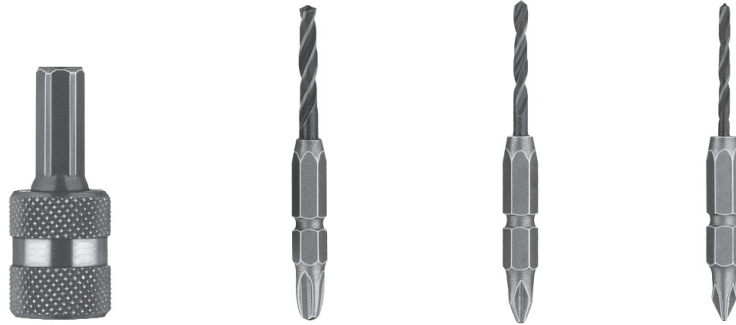

Tool set includes 1/4" quick release chuck with 3/8" hexagon shank to be fitted in a power tool and three unique drill and drive bit combinations which enable easy and fast way to change tool for drilling hole and screwing.

Model No.	A mm	B mm	Packaging style	Weight g
DSTS	20.5	54	Blister card	90

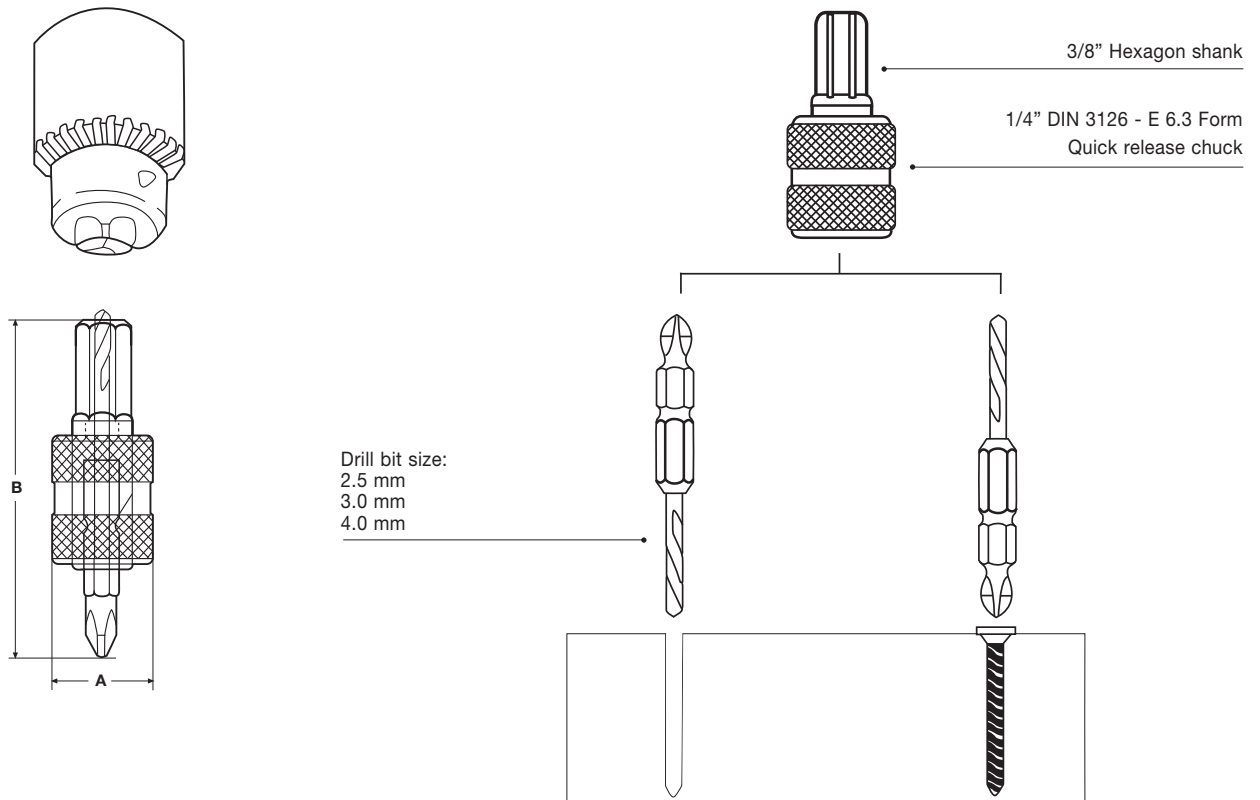

new



- ① Hexagon shank 1/4" Din 3126 Form E 6.3
- ② Housing: plastic material
- ③ Nosepiece: mm 2.4 – 3.2 – 4.0 – 4.8
- ④ Sight window: Blind rivet loading
- ⑤ Wrench with interchangeable noses

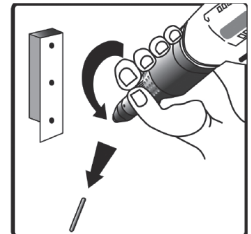
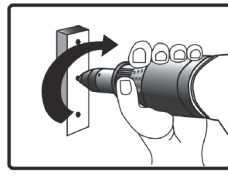
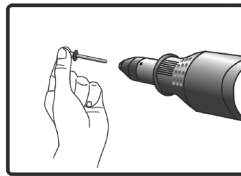
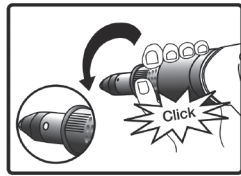
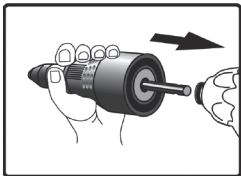

Description

Simply convert the standard cordless, electric, pneumatic drill / driver into a blind rivet gun.

- Accept 3/8" and 1/2" (10/13 mm) drill chuck or 1/4"(6.35mm) hex recess.
- Compatible with 12V,14.4V and 18V cordless drill / driver and any reversible corded drill I driver.
- Pull: Aluminum rivets: 2.4 - 4.8 mm
Stainless steel rivets: 2.4 - 4.0 mm
- Comes complete 2.4 – 3.2 – 4.0 – 4.8 mm (3/32" - 1/8"- 5/32" - 3/16") 4 nosepieces.
- Max rpm: 1000 rpm.
- The shank of rivet is expelled when the drill is operated in the "reverse" mode.
- If used with a combine impact drill, ensure that it is set to drilling mode.

Model No.	Mount	Aluminum rivets size mm	Steel rivets size mm	Maximum speed	Packaging style	Weight g
RIVCONV	1/4" DIN 3126 Form E 6.3	from 2.4 up to 4.8	from 2.4 up to 4.0	1000 rpm	Individual box	280



RACSDSV1

RACSDSIH

Model No.	Style	Description	Packaging style	Weight g
RACSDSV1	BOSCH SDS+	To convert SDS and other direct drive systems to accept 1/2" x 20 female chuck for rotary only work Supplied complete with M6 left hand threaded retaining screw	Individual box	55
RACSDSV1B			Blister card	55
RACSDSMAKB	MAKITA		Blister card	50
RACSDSIH magnetic	BOSCH	To convert SDS system to accept tools with 1/4" hexagon shanks for rotary rotation work	Bulk	50
RACSDSIHB magnetic	SDS+		Blister card	

Model No.	Description	Packaging style	Weight g
VSR10D5	M5 left hand thread spare screw total length 18 mm for use with 10 mm 3/8" x 24 threaded keyed chucks	Bulk	6
VSR10D6	M6 left hand thread spare screw total length 23 mm for use with 10 mm 1/2" x 20 threaded keyed chucks		
VSR13D6	M6 left hand thread spare screw total length 27 mm for use with SDS adaptors and 13 mm 1/2" x 20 threaded keyed chucks		



Model No.	Description	Packaging style	Weight g
RAC3812M	To convert 1/2" x 20 female to 3/8" x 24 male	Individual box	26
RAC3812MB		Blister card	
RAC3838M	To convert 3/8" x 24 female to 3/8" x 24 male	Individual box	19
RAC3838MB		Blister card	



Model No.	Description	Packaging style	Weight g
RAC3812F	To convert 1/2" x 20 female to 3/8" x 24 female	Individual box	11
RAC3812FB		Blister card	





new

Model No.	Description
RACX1SQ38B	1/4" hexagon adaptor to 3/8" square drive



new

Model No.	Description
RACX1WBHB	1/4" wobble type adaptor <ul style="list-style-type: none"> • locked: straight position • unlocked: wobble position up to 25°



new

Model No.	Description
RAC12SQ38B	Convert 1/2" x 20 thread to 3/8" square drive
RAC12SQ12B	Convert 1/2" x 20 thread to 1/2" square drive

new

Quick release 1/4" hexagon bit holders



Model No.	Description
RAC14HSQ14B	To be fitted on 1/4" square drive machine
RAC14HSQ38B	To be fitted on 3/8" square drive machine
RAC14HSQ12B	To be fitted on 1/2" square drive machine
RAC14HT38B	To be fitted on 3/8" x 24 threaded mount machine
RAC14HT12B	To be fitted on 1/2" x 20 threaded mount machine

Morse taper arbors with taper and threaded mounts, precision ground, hardened and tempered

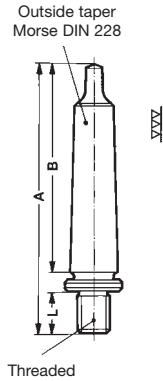
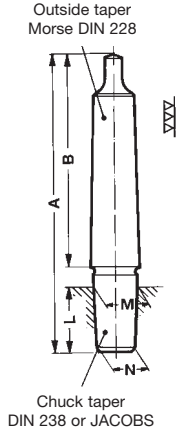

Model No.	Morse taper DIN 228	Chuck mount	A mm	B mm	M mm	N mm	L mm	Packaging style	Weight g
C1B10	1	DIN B10	83	65.5	10.094	9.4	14.5	Individual box	55
C1B12		DIN B12	89		12.065	11.1	18.5		65
C1B16		DIN B16	99		15.733	14.5	24.0		90
C1B18		DIN B18	99		17.780	16.2	32.0		110
C1J0		JACOBS 0	81		6.35	5.802	11.112		50
C1J1		JACOBS 1	86		9.754	8.468	16.67		50
C1J2		JACOBS 2	92		14.2	12.39	22.23		60
C1J3		JACOBS 3	102		20.6	18.95	30.96		60
C1J6		JACOBS 6	96		17.17	15.85	25.4		60
C1J33		JACOBS 33	96		15.85	14.24	25.4		60
C1F38		Thr. 3/8" x 24	83		-	-	14.3		60
C1F12		Thr. 1/2" x 20	85		-	-	14.3		60
C2B10	2	DIN B10	105	80	10.094	9.4	14.5	Individual box	130
C2B12		DIN B12	106		12.065	11.1	18.5		135
C2B16		DIN B16	112		15.733	14.5	24.0		160
C2B18		DIN B18	119		17.780	16.2	32.0		180
C2B22		DIN B22	130		21.793	19.8	40.5		245
C2J0		JACOBS 0	96		6.35	5.802	11.112		125
C2J1		JACOBS 1	101		9.754	8.468	16.67		130
C2J2		JACOBS 2	107		14.2	12.39	22.23		160
C2J3		JACOBS 3	117		20.6	18.95	30.96		200
C2J4		JACOBS 4	129		28.55	26.346	42.07		210
C2J6		JACOBS 6	111		17.17	15.85	25.4		165
C2J33		JACOBS 33	112		15.85	14.24	25.4		160
C2F38		Thr. 3/8" x 24	96		-	-	14.3		160
C2F12		Thr. 1/2" x 20	104		-	-	14.3		165
C2F58		Thr. 5/8" x 16	117		-	-	17.5		180
C2F34		Thr. 3/4" x 16	107		-	-	17.5		190
C3B12	3	DIN B12	125	99	12.065	11.1	18.5	Individual box	280
C3B16		DIN B16	134		15.733	14.5	24.0		310
C3B18		DIN B18	140		17.780	16.2	32.0		320
C3B22		DIN B22	147		21.793	19.8	40.5		390
C3B24		DIN B24	157		23.825	21.3	50.5		440
C3J1		JACOBS 1	125		9.754	8.468	16.67		290
C3J2		JACOBS 2	126		14.2	12.39	22.23		310
C3J3		JACOBS 3	136		20.6	18.95	30.96		350
C3J6		JACOBS 6	130		17.17	15.85	25.4		310
C3J33		JACOBS 33	130		15.85	14.24	25.4		310
C3J4		JACOBS 4	147		28.55	26.346	42.07		330
C3F38		Thr. 3/8" x 24	114		-	-	14.3		310
C3F12		Thr. 1/2" x 20	122		-	-	14.3		320
C3F58		Thr. 5/8" x 16	126		-	-	17.5		340
C3F34	Thr. 3/4" x 16	126	-	-	17.5	350			
C4B16	4	DIN B16	156	124	15.733	14.5	24.0	Individual box	625
C4B18		DIN B18	164		17.780	16.2	32.0		660
C4B22		DIN B22	176		21.793	19.8	40.5		715
C4B24		DIN B24	186		23.825	21.3	50.5		770
C4J2		JACOBS 2	153		14.2	12.39	22.23		600
C4J3		JACOBS 3	162		20.6	18.95	30.96		660
C4J4		JACOBS 4	173		28.55	26.346	42.07		700
C4J5		JACOBS 5	179		35.89	33.422	47.625		750
C4J6		JACOBS 6	156		17.17	15.85	25.4		650
C4J33	JACOBS 33	156	15.85	14.24	25.4	640			
C5B16	5	DIN B16	198	156	15.733	14.5	24.0	Individual box	1600
C5B18		DIN B18	198		17.780	16.2	32.0		1600
C5B22		DIN B22	207		21.793	19.8	40.5		1650
C5B24		DIN B24	217		23.825	21.3	50.5		1700
C5J3		JACOBS 3	198		20.6	18.95	30.96		1600
C5J4		JACOBS 4	210		28.55	26.346	42.07		1650
C5J5		JACOBS 5	216		35.89	33.422	47.625		1700
C5J6	JACOBS 6	198	17.17	15.85	25.4	1650			

Iso taper arbors hardened and tempered according to DIN 2080



Model No.	Iso taper	Chuck mount	Drawbolt thread	Packaging style	Weight g
ISO30J6	30	JACOBS 6	M12	Individual box	425
ISO30B12		DIN B12			420
ISO30B16		DIN B16			425
ISO40J6	40	JACOBS 6	M16	Individual box	970
ISO40B12		DIN B12			965
ISO40B16		DIN B16			970
ISO40B18		DIN B18			970
ISO50J6	50	JACOBS 6	M24	Individual box	2560
ISO50B16		DIN B16			
ISO50B18		DIN B18			

Parallel arbors with Jacobs taper mounts

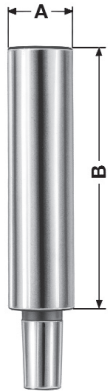

Model No.	A	B mm	Jacobs taper mount	Packaging style	Weight g
PA12J0	1/2"	64	0	Individual box	86
PA12J1			1		93
PA12J2			2		115
PA12J6			6		129
PA12J33			33		122
PA58J1	5/8"	64	1	Individual box	127
PA58J2			2		145
PA58J3			3		160
PA58J6			6		160
PA58J33			33		155
PA34J1	3/4"	72	1	Individual box	200
PA34J2			2		218
PA34J3			3		275
PA34J6			6		235
PA34J33			33		225
PA1J2	1"	74	2	Individual box	349
PA1J3			3		355
PA1J6			6		365
PA1J33			33		365

Bridgeport R8 taper adaptors for chucks with DIN or Jacobs mount

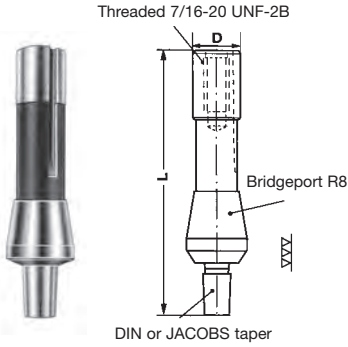

Model No.	Taper	Mount	D mm	L mm	Drawbolt thread	Packaging style	Weight g
CR8B16	Bridgeport R8	DIN B16	24.10	135	7/16"-20	Individual box	425
CR8J2	Bridgeport R8	JACOBS 2	24.10	132	7/16"-20	Individual box	400
CR8J3		JACOBS 3		141			460
CR8J6		JACOBS 6		135			430
CR8J33		JACOBS 33		135			420

Bridgeport R8 taper adaptors for Morse taper

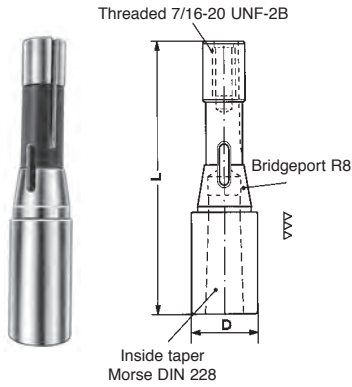

Model No.	Taper	Morse taper	D mm	L mm	Drawbolt thread	Packaging style	Weight g
CR8MT1	Bridgeport R8	1	32	124	7/16"-20	Individual box	450
CR8MT2		2		137			460
CR8MT3		3		139			320

Reducing sleeves according to DIN 2185, hardened and tempered, precision ground internally and externally



Model No.	Morse taper		A mm	B mm	C mm	D mm	E mm	Packaging style	Weight g
	inside	outside							
B01	0	- 1	80	19	12.065	9.045	13.0	Individual box	30
B12	1	- 2	92	17	17.780	12.065	18.6		95
B13	1	- 3	99	5	23.825	12.065	24.1		250
B23	2	- 3	112	18	23.825	17.780	24.7		190
B14	1	- 4	124	6.5	31.267	12.065	31.6		550
B24	2	- 4	124	6.5	31.267	17.780	31.6		480
B34	3	- 4	140	22.5	31.267	23.825	32.4		360
B15	1	- 5	156	6.5	44.399	12.065	44.7		1700
B25	2	- 5	156	6.5	44.399	17.780	44.7		1520
B35	3	- 5	156	6.5	44.399	23.825	44.7		1360
B45	4	- 5	171	21.5	44.399	31.267	45.5		1020
B36	3	- 6	218	8	63.348	23.825	63.8		5300
B46	4	- 6	218	8	63.348	31.267	63.8		5010
B56	5	- 6	218	8	63.348	44.399	63.8		4200

Oil toughened reducing sleeves externally precision ground with hardened tang

Outside taper Morse DIN 228

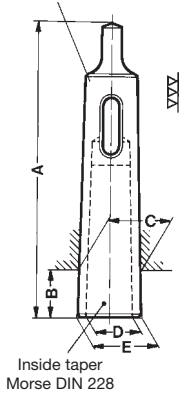

Model No.	Morse taper		A mm	B mm	C mm	D mm	E mm	Packaging style	Weight g
	inside	outside							
B01OT	0	- 1	80	19	12.065	9.045	13.0	Individual box	30
B12OT	1	- 2	92	17	17.780	12.065	18.6		95
B13OT	1	- 3	99	5	23.825	12.065	24.1		250
B23OT	2	- 3	112	18	23.825	17.780	24.7		190
B14OT	1	- 4	124	6.5	31.267	12.065	31.6		550
B24OT	2	- 4	124	6.5	31.267	17.780	31.6		480
B34OT	3	- 4	140	22.5	31.267	23.825	32.4		360
B15OT	1	- 5	156	6.5	44.399	12.065	44.7		1700
B25OT	2	- 5	156	6.5	44.399	17.780	44.7		1520
B35OT	3	- 5	156	6.5	44.399	23.825	44.7		1360
B45OT	4	- 5	171	21.5	44.399	31.267	45.5		1020
B36OT	3	- 6	218	8	63.348	23.825	63.8		5300
B46OT	4	- 6	218	8	63.348	31.267	63.8		5010
B56OT	5	- 6	218	8	63.348	44.399	63.8		4200

Reducing sleeves with plain through hole, hardened and tempered, precision ground internally and externally

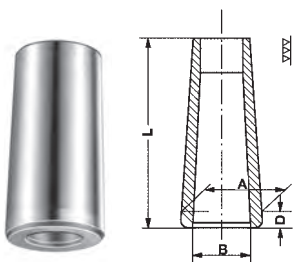

Model No.	Morse taper		L mm	D mm	A mm	B mm	Packaging style	Weight g
	inside	outside						
B12TH	1	- 2	50	4	17.780	12.065	Individual box	50
B13TH	1	- 3	55	4.5	23.825	12.065		140
B23TH	2	- 3	60	4.5	23.825	17.780		90
B14TH	1	- 4	65	5.3	31.267	12.065		320
B24TH	2	- 4	70	5.3	31.267	17.780		260
B34TH	3	- 4	75	5.3	31.267	23.825		170
B25TH	2	- 5	80	6.3	44.400	17.780		770
B35TH	3	- 5	90	6.3	44.400	23.825		740
B45TH	4	- 5	95	6.3	44.400	31.267		560
B36TH	3	- 6	110	7.9	63.380	23.825		2200
B46TH	4	- 6	120	7.9	63.380	31.267		2100
B56TH	5	- 6	125	7.9	63.380	44.400		1510

Morse taper turret sockets, hardened case, ground internally and externally

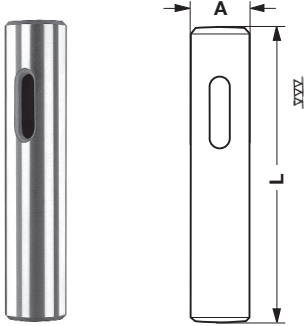
 Inside taper
Morse DIN 228

Model No.	Diameter A	Morse taper	L mm	Packaging style	Weight g
TS75MT1	3/4"	1	89	Individual box	280
TS1MT1	1"	1	89	Individual box	300
TS1MT2		2	102		
TS15MT1	1.1/2"	1	89	Individual box	600
TS15MT2		2	102		770
TS15MT3		3	121		820
TS15MT4		4	153		1150
TS2MT3	2"	3	121	Individual box	1500
TS2MT4		4	153		1800
TS2125MT3	2.1/8"	3	121	Individual box	1750
TS2125MT4		4	153		2100
TS2125MT5		5	228		2500
TS25MT3	2.1/2"	3	121	Individual box	2500
TS25MT4		4	153		2900
TS25MT5		5	228		4500
TSM20MT1	20 mm	1	89	Individual box	280
TSM25MT1	25 mm	1	89	Individual box	300
TSM25MT2		2	102		
TSM30MT3	30 mm	3	121	Individual box	750
TSM40MT2	40 mm	2	102	Individual box	770
TSM40MT3		3	121		820
TSM40MT4		4	153		1150
TSM50MT3	50 mm	3	121	Individual box	1750
TSM50MT4		4	153		2100

Iso taper to Morse taper adaptors according to DIN 2080 hardened and tempered, precision ground internally and externally

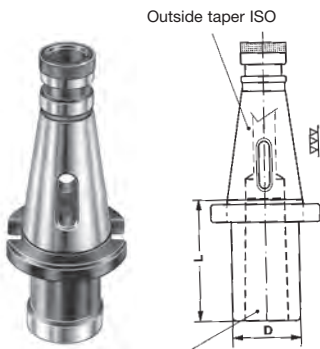
 Inside taper
Morse DIN 228

Model No.	Iso taper outside	Morse taper inside	D mm	L mm	Drawbolt thread	Packaging style	Weight g
ISO30MT2	30	2	34	50	M12	Individual box	400
ISO30MT3		3	40	70			600
ISO40MT2	40	2	34	50	M16	Individual box	900
ISO40MT3		3	40	65			1000
ISO40MT4		4	50	95			1300
ISO50MT3	50	3	40	65	M24	Individual box	2800
ISO50MT4		4	50	70			2800
ISO50MT5		5	65	105			3200

Extension sockets according to DIN 2187, hardened and tempered, precision ground internally and externally



Model No.	Morse taper outside	Morse taper inside	a ₁ mm	a ₂ mm	d ₁ mm	d ₂ mm	d ₃ mm	l ₁ mm	l ₂ mm	Packaging style	Weight g
BL11145	1	1	-	7	12.065	12.065	20	145	83	Individual box	190
BL12160		2				17.780	30	160	98		250
BL21160	2	1	-	9	17.780	12.065	20	160	85	Individual box	340
BL22175		2				17.780	30	175	100		400
BL23196		3				23.825	36	196	121		550
BL31175	3	1	5	-	23.825	12.065	20	175	81	Individual box	400
BL32194		2	-	9		17.780	30	194	100		840
BL33215		3	-	9		23.825	36	215	121		1000
BL34240		4	-	9		31.267	48	240	146		1300
BL41200	4	1	6.5	-	31.267	12.065	20	200	82.5	Individual box	800
BL42215		2	6.5	-		17.780	30	215	97.5		850
BL43240		3	-	10.5		23.825	36	240	122.5		1500
BL44265		4	-	10.5		31.267	48	265	147.5		1900
BL45300		5	-	10.5		44.399	63	300	182.5		2750
BL51232	5	1	6.5	-	44.399	12.065	20	232	82.5	Individual box	1600
BL52247		2	6.5	-		17.780	30	247	97.5		1600
BL53268		3	6.5	-		23.825	36	268	118.5		2840
BL54300		4	-	13.5		31.267	48	300	150.5		3310
BL55335		5	-	13.5		44.399	63	335	185.5		4200

Oil toughened extension sockets externally precision ground with hardened tang

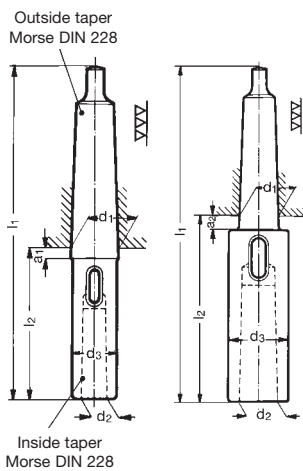

Model No.	Morse taper outside	Morse taper inside	a ₁ mm	a ₂ mm	d ₁ mm	d ₂ mm	d ₃ mm	l ₁ mm	l ₂ mm	Packaging style	Weight g
BL11145OT	1	1	-	7	12.065	12.065	20	145	83	Individual box	190
BL12160OT		2				17.780	30	160	98		250
BL21160OT	2	1	-	9	17.780	12.065	20	160	85	Individual box	340
BL22175OT		2				17.780	30	175	100		400
BL23196OT		3				23.825	36	196	121		550
BL31175OT	3	1	5	-	23.825	12.065	20	175	81	Individual box	400
BL32194OT		2	-	9		17.780	30	194	100		840
BL33215OT		3	-	9		23.825	36	215	121		1000
BL34240OT		4	-	9		31.267	48	240	146		1300
BL41200OT	4	1	6.5	-	31.267	12.065	20	200	82.5	Individual box	800
BL42215OT		2	6.5	-		17.780	30	215	97.5		850
BL43240OT		3	-	10.5		23.825	36	240	122.5		1500
BL44265OT		4	-	10.5		31.267	48	265	147.5		1900
BL45300OT		5	-	10.5		44.399	63	300	182.5		2750
BL51232OT	5	1	6.5	-	44.399	12.065	20	232	82.5	Individual box	1600
BL52247OT		2	6.5	-		17.780	30	247	97.5		1600
BL53268OT		3	6.5	-		23.825	36	268	118.5		2840
BL54300OT		4	-	13.5		31.267	48	300	150.5		3310
BL55335OT		5	-	13.5		44.399	63	335	185.5		4200

**Oil toughened long pattern extension sockets
externally precision ground with hardened tang**

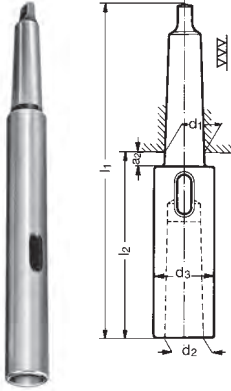

Model No.	Morse taper outside	Morse taper inside	a ₁ mm	a ₂ mm	d ₁ mm	d ₂ mm	d ₃ mm	l ₁ mm	l ₂ mm	Packaging style	Weight g	
BL11200OT	1	-	1	-	7	12.065	12.065	20	200	138	Individual box	250
BL11250OT									250	188		375
BL11300OT									300	238		500
BL11350OT									350	288		625
BL11400OT									400	338		750
BL11450OT									450	388		875
BL11500OT									500	438		1000
BL22200OT	2	-	2	-	9	17.780	17.780	25	200	125	Individual box	430
BL22250OT									250	175		625
BL22300OT									300	225		820
BL22350OT									350	275		1015
BL22400OT									400	325		1200
BL22450OT									450	375		1400
BL22500OT									500	425		1600
BL22600OT	600	525	1800									
BL33250OT	3	-	3	-	9	23.825	23.825	32	250	156	Individual box	1000
BL33300OT									300	206		1300
BL33350OT									350	256		1550
BL33400OT									400	306		1850
BL33450OT									450	356		2100
BL33500OT									500	406		2400
BL33600OT	600	506	2700									
BL44300OT	4	-	4	-	10.5	31.267	31.267	40	300	182.5	Individual box	1650
BL44350OT									350	232.5		2150
BL44400OT									400	282.5		2650
BL44450OT									450	332.5		3100
BL44500OT									500	382.5		3600
BL44600OT									600	482.5		4200



Carbon steel full point 60°

Model No.	Morse taper	A mm	B mm	Packaging style	Weight g
CFN1	1	12.2	80	Individual box	60
CFN2	2	18	100		150
CFN3	3	24.1	125		340
CFN4	4	31.6	160		790
CFN5	5	44.7	200		1920
CFN6	6	63.8	270		5200



Carbon steel half point 60°

Model No.	Morse taper	A mm	B mm	E mm	F mm	Packaging style	Weight g
CFR1	1	12.2	80	7.6	22	Individual box	55
CFR2	2	18	100	11	30		145
CFR3	3	24.1	125	15	38		310
CFR4	4	31.6	160	21	50		740
CFR5	5	44.7	200	29.4	63		1800
CFR6	6	63.8	270	42	79		4800



Carbide tipped full point 60°

Model No.	Morse taper	A mm	B mm	D mm	Packaging style	Weight g
CFW1	1	12.2	80	7	Individual box	60
CFW2	2	18	100	7		150
CFW3	3	24.1	125	11		340
CFW4	4	31.6	160	14		790
CFW5	5	44.7	200	18		1920
CFW6	6	63.8	270	18		5200



Carbide tipped half point 60°

Model No.	Morse taper	A mm	B mm	D mm	E mm	F mm	Packaging style	Weight g
CFWR1	1	12.2	80	7	7.6	22	Individual box	55
CFWR2	2	18	100	7	11	30		145
CFWR3	3	24.1	125	11	15	38		310
CFWR4	4	31.6	160	14	21	50		740
CFWR5	5	44.7	200	18	29.4	63		1800
CFWR6	6	63.8	270	18	42	79		4800

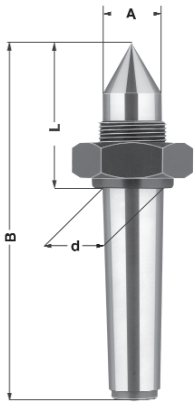

Standard point completely hardened and ground

Model No.	Morse taper	A thread	B mm	d mm	L mm	Packaging style	Weight g
CDN1	1	M16x1.5	90	12.065	36.5	Individual box	140
CDN2	2	M22x1.5	112	17.780	48		300
CDN3	3	M27x1.5	138	23.825	57		580
CDN4	4	M36x1.5	175	31.267	72.5		800
CDN5	5	M48x1.5	217	44.399	87.5		2900
CDN6	6	M68x1.5	290	63.348	108		7200

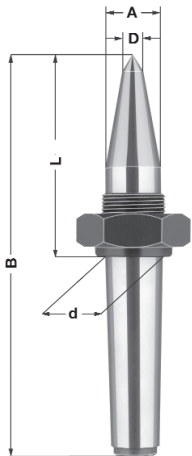

Extended point completely hardened and ground

Model No.	Morse taper	A thread	B mm	D mm	d mm	L mm	Packaging style	Weight g
CCDN1	1	M16x1.5	93	5	12.065	36.5	Individual box	170
CCDN2	2	M22x1.5	118	10	17.780	54		300
CCDN3	3	M27x1.5	148	10	23.825	67		600
CCDN4	4	M36x1.5	186.5	14	31.267	84		1285
CCDN5	5	M48x1.5	242	16	44.399	112		3000
CCDN6	6	M68x1.5	330	20	63.348	148		7900

Spare draw off nuts

Model No.	Morse taper	Thread
DNM16	1	M16x1.5
DNM22	2	M22x1.5
DNM27	3	M27x1.5
DNM36	4	M36x1.5
DNM48	5	M48x1.5
DNM68	6	M68x1.5

General purpose

Model No.	Morse taper	D mm	d mm	d ₁ mm	L mm	A mm	B mm	C mm	Max workpiece weight kg	Max speed r.p.m.	Max runout mm	Packaging style	Weight g
M1	1	28	10	12.06	51	16	30	105	80	3800	0.008	Individual box	200
M2	2	41	18	17.78	75	25	40	139	180	3800			550
M3	3	50	23	23.82	90	34	48	172	270	3500			970
M4	4	60	25	31.26	99	35	52	202	550	3500			1550
M5	5	75	38	44.39	130	52	65	259	1000	3000	0.012		3200
M6	6	96	50	63.34	156	65	82	338	1500	2600	0.015		7500

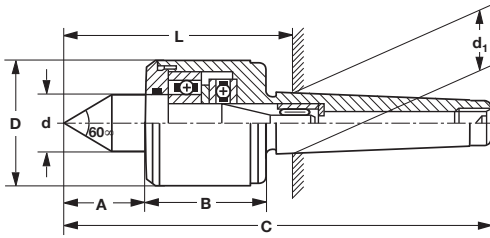

Reduced body diameter

Model No.	Morse taper	D mm	d mm	d ₁ mm	L mm	A mm	B mm	C mm	Max workpiece weight kg	Max speed r.p.m.	Max runout mm	Packaging style	Weight g
MR2	2	32	15	17.78	62	20	37	128	200	6000	0.005	Individual box	300
MR3	3	34	15	23.82	63	20	38	141	400	6000	0.005		500
MR4	4	42	20	31.26	76	26	42	180	800	6000	0.005		1000
MR5	5	58	30	44.39	105	35	62	238	1200	4000	0.008		2500

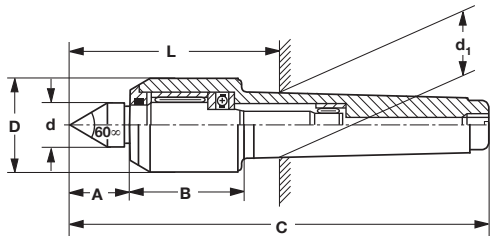

Woodworking

Model No.	Morse taper	D mm	d mm	d ₁ mm	L mm	A mm	B mm	C mm	Max workpiece weight kg	Max speed r.p.m.	Max runout mm	Packaging style	Weight g
MW1	1	32	15	12.06	53.5	20	26.8	108	2.5	6200	0.03	Individual box	215
MW2	2	32	15	17.78	56.8	20	28.1	119	4	6200	0.03		280

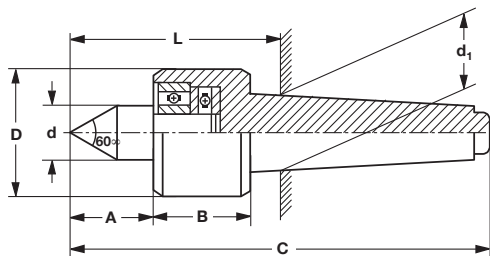

Extended point for copy turning machines

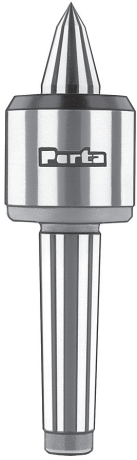

Model No.	Morse taper	D mm	d mm	d ₁ mm	L mm	A mm	B mm	C mm	E mm	Max workpiece weight kg	Max speed r.p.m.	Max runout mm	Packaging style	Weight g
MC3	3	50	23	23.82	90	35	48	171	11	270	4200	0.008	Individual box	970
MC4	4	60	25	31.26	101	39	52	205	14	550	3800			1550
MC5	5	75	38	44.39	131	53	65	260	20	1000	3000			3200

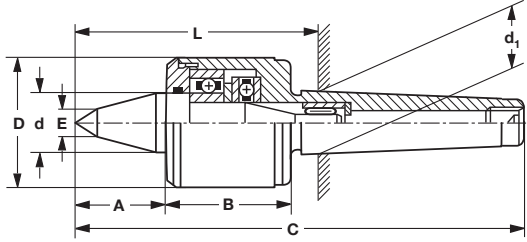

Reduced body diameter extended point for copy turning machines



Model No.	Morse taper	D mm	d mm	d ₁ mm	L mm	A mm	B mm	C mm	E mm	Max workpiece weight kg	Max speed r.p.m.	Max runout mm	Packaging style	Weight g
MRC2	2	32	15	17.78	71	29	37	137	8	150	6000	0.005	Individual box	300
MRC3	3	34	15	23.82	73	30	38	151	8	300	6000			500
MRC4	4	42	20	31.26	86	36	42	190	10	700	6000			1000
MRC5	5	58	30	44.39	116	46	62	249	12	1000	4000	0.01		2500

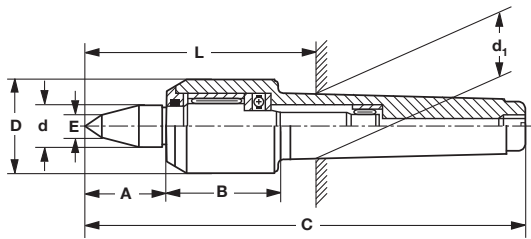

Chuck taper mount dimensions according to DIN 238 and Jacobs norms

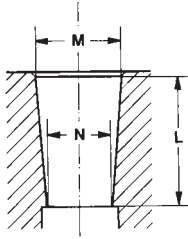

Norm	Chuck taper mount	M mm	N mm	L mm
DIN 238	B6	6.35	5.85	10.0
	B10	10.094	9.4	14.5
	B12	12.065	11.1	18.5
	B16	15.733	14.5	24.0
	B18	17.780	16.2	32.0
	B22	21.793	19.8	40.5
	B24	23.825	21.3	50.5
JACOBS	J0	6.350	5.803	11.11
	J1	9.754	8.468	16.67
	J2	14.2	12.39	22.23
	J2 short	13.94	12.39	19.05
	J33	15.85	14.24	25.4
	J6	17.17	15.85	25.4
	J3	20.6	18.95	30.96
	J4	28.55	26.35	42.07

Chuck threaded mount dimensions

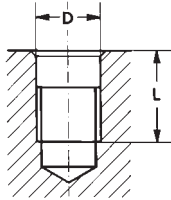

Threaded mount	Class	D mm	Pitch mm	L mm
3/8" x 24 UNF	3B	9.525	1.058	14.5
1/2" x 20 UNF	3B	12.700	1.270	16.0
5/8" x 16 UN	3B	15.875	1.588	19.0
3/4" x 16 UNF	3B	19.050	1.588	19.0
M14 x 2	MA	14.00	2.00	19.0
M18 x 2.5	MA	18.00	2.50	19.0

Morse taper dimensions according to DIN 228



Morse taper	A mm	B mm	C mm	D mm	E mm	F mm	Taper %
0	59.5	56.5	9.045	6.1	3.9	9.2	5.205
1	65.5	62.0	12.065	9.0	5.2	12.2	4.988
2	80.0	75.0	17.780	14.0	6.3	18.0	4.995
3	99.0	94.0	23.825	19.1	7.9	24.1	5.020
4	124.0	117.5	31.267	25.2	11.9	31.6	5.194
5	156.0	149.5	44.399	36.5	15.9	44.7	5.263
6	218.0	210.0	63.348	52.4	19.0	63.8	5.214

Iso taper dimensions according to DIN 2080

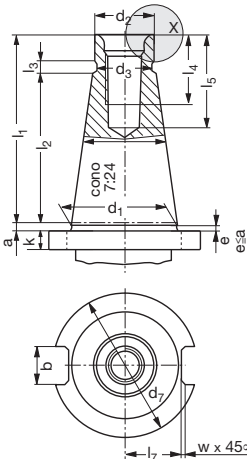

Iso taper	a mm	b mm	d ₁ mm	d ₂ mm	d ₃ mm	d ₄ mm	d ₅ mm	d ₆ mm	d ₇ mm	k mm	l ₁ mm	l ₂ mm	l ₃ mm	l ₄ mm	l ₅ mm	l ₆ mm	l ₇ mm	w mm
30	1.6	16.1	31.75	17.11	16.5	M12	13	16	50	8	68.4	48.4	3	24	33.5	5.5	16.2	1.6
40	1.6	16.1	44.45	25	24	M16	17	21.5	63	10	93.4	65.4	5	32	42.5	8.2	22.5	1.6
50	3.2	25.7	69.85	39.30	38	M24	26	32	97.5	12	126.8	101.8	8	47	61.5	11.5	35.3	2

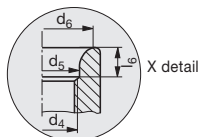

A large empty rectangular box with a thin black border, intended for a note or additional information.

A large empty rectangular box with a thin black border, intended for handwritten notes.



PORTA Srl

Via Sommariva 33/12
10022 Carmagnola (TO)
Italy

T: +39 011 9710018
F: +39 011 9712547
E: porta@portachucks.com
www.portachucks.com

PORTA (U.K.) Ltd

Dukeries Way
Dukeries Industrial Estate
Worksop, Notts S81 7DW
England

T: +44 1909 530135
F: +44 1909 501589
E: sales@portauk.co.uk
www.portaplus.co.uk